



PROSECRS

Vehicle Security / Remote Start System

Installation and Reference Guide

Thank you for trusting Pursuit products! **If you are a consumer, please note: Professional installation is strongly recommended.**

This manual assumes the installer has adequate knowledge of the following expertise. Therefore, it does not cover these topics in detail:

- **12-volt electronics**
- **Testing and verifying circuits**
- **Making safe and lasting wiring connections**
- **Factory ignition, power, lighting, data bus and sensing systems**
- **Factory systems and components to avoid**
- **Safe wire routing, circuit protection and product placement**
- **Access to vehicle-specific technical information**

In addition, this manual assumes the installer has the **proper tools, skill and facilities** to perform a professional installation. **Performing an improper installation could result in damage to the vehicle or its components, improper system function, unsafe vehicle operation or physical injury.** Such instances would not be covered by the vehicle manufacturer's warranty, nor by Voxx Electronics, Inc.

Detailed Descriptions

2 Wire Harness Colors and Functions

- 2 [Power Connector](#)
- 3 [Alarm / Notification Connector](#)
- 4 [Input / Output Connector](#)

7 External Components

- 7 [Shock Sensor](#)
- 7 [RF Antenna Kit](#)
- 7 [Data Bus Interface \(FLCART / DBI\)](#)
- 7 [Telematics](#)

8 Setup Options

- 8 [Remote Programming](#)
- 9 [Security Control](#)
- 13 [Remote Start Control](#)
- 17 [Negative Output Control \(NOC\)](#)
- 19 [AUX Output Control](#)
- 20 [PIC Input Control](#)

21 System Operation

- 21 [Manual Transmission Mode](#)
- 22 [Remote Operation](#)

Quick Reference

23 Setup Options

- 23 [Programming Mode Entry / Exit](#)
- 24 [Feature Bank Options](#)

25 Programming & Diagnostics

- 25 [Data Port Protocol Selection](#)
- 25 [Tach Function](#)
- 25 [Dome Light Delay](#)
- 26 [2 / 4 Hour Timer](#)
- 26 [Turbo Timer](#)
- 26 [Silent Arm and Disarm](#)
- 27 [User Selectable LED](#)
- 27 [Adjusting Shock Sensor](#)
- 27 [Troubleshooting Trigger Zones](#)
- 27 [Troubleshooting Remote Start](#)
- 28 [Alarm Override Procedures](#)

29 Wiring Diagrams

- 29 [Door Lock Connections](#)
- 32 [Starter Kill Relay](#)
- 33 [Full System Connections](#)

Detailed Descriptions: Wire Harness Colors and Functions

Power Connector (8-pin High-Current Connector) [See page 33 for the full system diagram.](#)

These wires are listed in order of their placement in the harness connector.

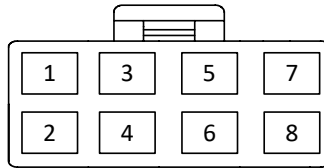

1. RED/BLACK – Ignition 3, Flex Relay Input (Internal Relay Pin 87)

The RED/BLACK wire is used to supply the Pin 2 - PINK Flex Relay Output. This wire can be connected to 12-Volt (+) or Ground (-). Please check vehicle requirements for correct polarity.

Note: Before making this connection, remove all module fuses until the system is completely connected.

2. PINK – Ignition 3 Flex Relay Output (Internal Relay Pin 30)

At its default setting, the PINK wire supplies 12-Volt (+) or Ground (-) to the vehicle's secondary ignition wire during remote start. The polarity of this output is provided by the Pin 1, RED/BLACK Input.

Verification: If present, the secondary ignition wire registers 12-Volt (+) or Ground (-) when the vehicle is in ignition mode AND during engine crank.

Note: This wire can be programmed to perform a different function by changing its options. [Refer to Bank 3, Feature 8 on page 13.](#)

3. YELLOW – Starter Output for Remote Start (+)

The YELLOW wire supplies 12-Volt (+) to the vehicle's starter wire when remote start is enabled, and turns off once the vehicle is started.

Verification: This starter wire registers 12-Volt (+) during engine crank.

Note: If installing a starter kill relay in addition to remote start, connect the YELLOW wire to the MOTOR SIDE of the cut starter wire. [Refer to Start Kill diagram on page 32.](#)

4. GREEN – Ignition 2 Output (+)

At its default setting, the GREEN wire supplies 12-Volt (+) to the vehicle's secondary ignition wire during remote start.

Verification: If present, the secondary ignition wire registers 12-Volt (+) when the vehicle is in ignition mode AND during engine crank.

Note: This wire can be programmed to perform a different function by changing its options. [Refer to Bank 3, Feature 7 on page 13.](#)

5. RED – 12-Volt Input (+)

The RED wire connects to the vehicle's primary 12-Volt (+) wire to power the system.

Verification: The power wire registers 12-Volt (+) at all times.

Note: Before making this connection, remove all module fuses until the system is completely connected.

6. RED/WHITE – 12-Volt Input (+)

The RED/WHITE wire connects to the vehicle's secondary 12-Volt (+) wire to power the remote start function.

Verification: The power wire registers 12-Volt (+) at all times.

Note: Before making this connection, remove all module fuses until the system is completely connected.

Detailed Descriptions: Wire Harness Colors and Functions

Power Connector (8-pin High-Current Connector) (Cont) [See page 33 for the full system diagram.](#)

These wires are listed in order of their placement in the harness connector.

7. PURPLE – Accessory Output (+)

At its default setting, the Purple wire supplies 12-Volt (+) to the vehicle's accessory wire to power vehicle accessories during remote start.

Verification: The accessory wire registers 12-Volt (+) when the vehicle is running or in accessory mode, but not during engine crank or if the vehicle is off.

Note: This wire can be programmed to perform a different function by changing its options. [Refer to Bank 3, Feature 9 on page 13.](#)

8. BLUE – Ignition 1 Input / Output (+)

The BLUE wire supplies 12-Volt (+) to the vehicle's primary ignition wire during remote start. This wire is also used to sense vehicle ignition for the Programming Functions

Verification: The primary ignition wire registers 12-Volt (+) when the vehicle is in ignition mode AND during engine crank.

Alarm / Notification Connector (4-pin connector) [See page 33 for the full system diagram.](#)

These wires are listed in order of their placement in the harness connector.

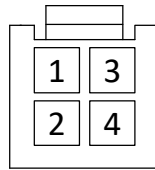

1. WHITE – Parking Light Relay Output (Internal Relay Pin 30)

At its default setting, the WHITE wire supplies 12-Volt (+) or Ground (-) to the vehicle's park light wire based on the connection of the relay input (WHITE/RED wire).

Verification: The vehicle parking light wire registers 12-Volt (+) or Ground (-) when the park lights are turned on.

Note: This wire can be programmed to perform the **Trunk Release Output** function by changing its options. [Refer to Bank 2, Feature 14 on page 9.](#)

2. WHITE/RED – Parking Light Relay Input (Internal Relay Pin 87)

The WHITE/RED connects to vehicle 12-Volt (+) or Ground (-) to supply the relay output (WHITE wire).

Verification for default setting:

- If the vehicle parking light wire registers 12-Volt (+) when the park lights are on, connect the WHITE/RED wire to a constant 12-Volt (+) vehicle wire.
- If the vehicle parking light wire registers Ground (-) when the park lights are on, connect the WHITE/RED wire to a reliable vehicle ground source.

Note: This wire can be programmed to perform the **Trunk Release Output** function by changing its options. [Refer to Bank 2, Feature 14 on page 9.](#)

3. WHITE/BLACK – Siren Output (+)

The WHITE/BLACK wire supplies 12-Volt (+) to power the siren. After mounting the siren, connect its BLACK wire to a reliable ground source, and connect the WHITE/BLACK wire to the siren's RED wire.

4. BLACK – Ground Input (-)

The BLACK wire connects to a reliable vehicle ground (-) source to power the system.

Verification: The vehicle ground (-) source wire registers ground (-) at all times.

Note: Before making this connection, remove all module fuses until the system is completely connected.

Detailed Descriptions: Wire Harness Colors and Functions

Input / Output Connector (22-pin connector) [See page 33 for the full system diagram.](#)

These wires are listed in order of their placement in the harness connector.

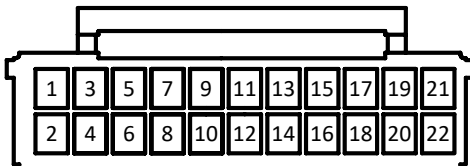

1. ORANGE – Starter Kill Output (-)

The ORANGE wire supplies Ground (-) when the alarm is armed and when the remote start is ON.

2. LIGHT GREEN – Trunk / Hatch Input (-) (PIC1)

The LIGHT GREEN wire connects a device or switch that, when triggered, supplies a Ground (-) output. If the system is armed, this input will trigger the alarm. **Note:** This wire is programmable. [Refer to PIC Programming on page 20.](#)

3. GRAY/BLACK – Hood Input (-) (PIC2)

The GRAY/BLACK wire connects to the vehicle's hood switch, or an installed switch that registers Ground (-) when triggered. **Note:** This wire is programmable. [Refer to PIC Programming on page 20.](#)

Verification: The vehicle hood switch wire registers Ground (-) when the hood is opened.

4. GREEN/ORANGE – Tach Input

The GREEN/ORANGE wire connects to the vehicle's tach wire at the negative side of the ignition coil or fuel injector to control engine crank during remote start.

Verification:

- Using a voltmeter set to AC volts, connect the voltmeter's positive lead to a constant vehicle 12-Volts (+) source and the negative lead to the wire to be tested.
- Start the engine and have a partner slowly press the gas pedal while the transmission is in Park. If the voltage increases as the RPM increases, this is the proper tach wire.

5. LIGHT BLUE – Remote Start Status Output (-) (NOC 1)

The LIGHT BLUE wire supplies Ground (-) as soon as the remote starter is activated and remains active until 4 seconds after remote start run time has ended. This wire is most commonly used to activate data integration modules.

Note: This wire is programmable. [Refer to NOC Programming on page 11.](#)

6. PURPLE/BROWN – Door Trigger Input (-/+)

The PURPLE/BROWN wire connects to the vehicle's door trigger wire. This wire will detect 12-Volt (+) or Ground (-) input.

Verification: The vehicle door trigger wire registers 12-Volt (+) or Ground (-) when a door is opened and opposite when closed.

Note: Programming is required if the door trigger wire registers 12-Volt (+). [Refer to Feature Programming on page 9.](#)

7. GREEN/WHITE – Dome Light Output (-) (NOC 2)

The GREEN/WHITE wire supplies Ground (-) when Unlock is activated from the Remote Control. This output will automatically turn off after 30 seconds.

Note: This wire is programmable. [Refer to NOC Programming on page 17.](#)

8. GREEN/YELLOW – Diesel Glow Plug Input (+) (PIC3)

The GREEN/YELLOW wire connect to the vehicle's Diesel Glow Plug detection wire.

Verification: This wire will register as 12-Volt (+) while the Diesel Wait to Start Light is illuminated.

Note: This wire is programmable. [Refer to PIC Programming on page 20.](#)

9. BLACK/YELLOW – Pulse During Crank Output (-) (NOC 3)

At its default setting, the BLACK/YELLOW wire supplies a Ground (-) pulse when the engine cranks during remote start.

Note: This wire is programmable. [Refer to NOC Programming on page 17.](#)

Detailed Descriptions: Wire Harness Colors and Functions

Input / Output Connector (22-pin connector) (Cont.) [See page 33 for the full system diagram.](#)

These wires are listed in order of their placement in the harness connector.

10. ORANGE/BLACK – Parking Brake Input (-) (PIC4)

The ORANGE/BLACK wire connects to the vehicle's parking brake wire to supply parking brake status for remote start.

Verification: The vehicle parking brake wire registers Ground (-) once the parking brake is engaged.

Note: This connection is only applicable to vehicles with manual transmission, or if the turbo timer setting is active

[\(System Programming: Bank 3, Features 10 & 16 on page 13\).](#)

Note: This wire is programmable. [Refer to PIC Programming on page 20.](#)

11. BLACK/RED – Pulse After Shutdown Output (-) (NOC 4)

At its default setting, the BLACK/RED wire supplies a Ground (-) pulse when the remote start system is shut down. It is typically used to re-lock vehicle doors after remote start shutdown, or pulse the vehicle's door trigger to turn off accessories after vehicle shutdown.

Note: This wire is programmable. [Refer to NOC Programming on page 17.](#)

12. DARK BLUE/BLACK -- External Start Input (-) (PIC5)

The DARK BLUE wire connects to a device or switch that, when triggered, supplies a Ground (-) output. If the vehicle ignition is off, this input will activate the remote start function. **Note:** This wire is programmable. [Refer to PIC](#)

[Programming on page 20.](#)

13. BLACK/BLUE – Factory Disarm Output (-) (NOC 5)

The BLACK/BLUE wire supplies a Ground (-) pulse when the system is disarmed and when remote start is activated.

Verification: In most vehicles the vehicle factory disarm wire registers Ground (-) if the driver door key cylinder is turned to the unlock position. **Note:** This wire is programmable. [Refer to NOC Programming on page 17.](#)

14. BROWN/BLACK – Brake Input (+) (PIC6)

The BROWN/BLACK wire connects to the vehicle's brake wire to supply brake status for remote start.

Verification: The vehicle brake wire registers 12-Volts (+) when the brake is activated. **Note:** This wire is programmable.

[Refer to PIC Programming on page 20.](#)

15. BLACK/LIGHT GREEN – Factory Arm Output (-) (NOC 6)

At its default setting, the BLACK/LIGHT GREEN wire supplies a Ground (-) pulse when the system is armed and when the vehicle has been successfully started using remote start. It is typically used to re-lock vehicle doors after remote start if necessary. **Note:** This wire is programmable. [Refer to NOC Programming on page 17.](#)

16. RED/BLACK – 2nd Unlock Output (-) (NOC 12)

At its default setting, the RED/BLACK wire supplies a Ground (-) pulse when the Unlock button is pressed 2x within 10 seconds. This requires Feature Bank 2, Feature 10, to be programmed ON. *Additional Parts may be required.*

Note: This wire is programmable. [Refer to NOC Programming on page 17.](#)

17. LIGHT BLUE/GREEN – Ch. 5 Aux. Output (-) (NOC 7)

The LIGHT BLUE/GREEN wire supplies Ground (-) when activated from the remote control.

Note: This wire is programmable. [Refer to NOC Programming on page 17.](#)

18. BLACK/WHITE – Horn Output (-)

The BLACK/WHITE wire connects to the vehicle's horn wire and supplies Ground (-) when activated from the system.

Verification: The vehicle horn wire registers Ground (-) when the horn is activated.

19. GREEN/LIGHT BLUE – Ch. 4 Aux. Output (-) (NOC 8)

The GREEN/LIGHT BLUE wire supplies Ground (-) when activated from the remote control.

Note: This wire is programmable. [Refer to NOC Programming on page 17.](#)

Detailed Descriptions: Wire Harness Colors and Functions

Input / Output Connector (22-pin connector) (Cont.) [See page 30 for the full system diagram.](#)

These wires are listed in order of their placement in the harness connector.

20. RED – Door Lock (-) (NOC 10)

The RED wire supplies Ground (-) when the Lock function is activated from the remote control or system.

Verification: The vehicle lock wire registers 12-Volts (+) or Ground (-) when the Lock button is activated. Additional parts may be required. [See Page 29 for common door lock wire diagrams.](#)

Note: [This wire is programmable. Refer to NOC Programming on page 17.](#)

21. DARK BLUE – Trunk Release Output (-) (NOC 9)

At its default setting, the DARK BLUE wire connects to the vehicle trunk release wire or relay and supplies Ground (-) when activated from the remote control.

Verification: The vehicle trunk release wire registers 12-Volt (+) or Ground (-) when the trunk release button is activated.

Note: This wire can be programmed to perform the **Parking Lights Output** function by changing its options. [Refer to Bank 2, Feature 14 on page 9 and NOC Programming on page 17.](#)

22. GREEN – Door Unlock (-) (NOC 11)

The GREEN wire supplies Ground (-) when the Unlock function is activated from the remote control or system.

Verification: The vehicle lock wire registers 12-Volt (+) or Ground (-) when the Unlock button is activated. Additional parts may be required. [See Page 29 for common door lock wire diagrams.](#)

Note: [This wire is programmable. Refer to NOC Programming on page 17.](#)

Detailed Descriptions: External Components

Shock Sensor

The shock sensor plugs into a 4-pin connector on the Pursuit module. It should be securely attached to a vehicle surface or sturdy wire harness. Testing takes place after all connections are made and the system is powered up. [Refer to Quick Reference: System Diagnostics on page 26](#) for instructions on testing and adjusting the shock sensor.

RF Antenna / LED / Programming Port

The long-range antenna kit (sold separately) plugs into a 4-pin connector on the Pursuit module.

1. Mount the supplied antenna/receiver to a clear spot on the vehicle's windshield that will not block the driver's vision. A suitable location is high on the windshield near the rear-view mirror.
2. Be careful not to mount the antenna/receiver on any metallic window film, as this will affect system range.
3. Route the antenna/receiver cable to the Pursuit module, ensuring it does not block or interfere with deployment of the airbag (if equipped.) Plug into the antenna port.

Data Bus Interface (DBI) Port

The 4-pin Data Bus Interface enables a FlashLogic door lock or transponder interface to connect to and communicate with the vehicle data bus. The combined system saves installation time as many features that normally require individual connection can be accessed and controlled through the data bus. Please refer to the D2D (Data to Data) function list available per vehicle at www.FlashLogic.com.

FLCART Cartridge Port

This port is for installing the FlashLogic FLCART data immobilizer & door lock interface cartridge used to communicate with the vehicle's databus.

Weblink Programming Port

This 4-pin port is used for programming the FlashLogic FLCART interface cartridge via the FLPROG Weblink or Weblink Mobile. Refer to the FlashLogic website for more details.

FLCART Harness Port

This port is for the harness included with the FLCART interface cartridge. Refer to the FlashLogic website for more details.

Telematics Interface Port

The 4-pin Telematics port enables a connected interface such as CarLink to expand system control to a smartphone or tablet. The following features may be able to be activated from a connected device:

- Door Lock Control
- Remote Start
- Trunk Release
- Auxiliary Output
- Sliding Doors

Detailed Descriptions: Setup Options

Bank 1: Add / Remove Remote Controls

Remote programming is located in Feature Bank 1. This system will Auto Program basic functions of the remote with one (1) button press. Basic functions are channels 1-3, Lock, Unlock, and Trunk / Start.

Feature Bank 1		Description	
Channel	1	Auto Program/Lock	Press Lock button on remote
	2	Unlock	Press Unlock button on remote
	3	Trunk/Start	Press Trunk/Start button on remote
	4	Ch. 4 AUX	Press button/buttons to control AUX Ch. 4
	5	Ch. 5 AUX	Press button/buttons to control AUX Ch. 5
	6	Ch. 6 AUX	Press button/buttons to control AUX Ch. 6
	7	Ch. 7 AUX	Press button/buttons to control AUX Ch. 7

To Auto Program a remote control:

1. Turn the ignition key to ON.
2. Press and release the valet/override button three (3) times.
3. The system will beep one (1) time, indicating you have accessed Bank 1, Remote Programming.
4. Press the Lock button of each remote control you wish to program. (Channels 1-3 of the remote control will be programmed.) The system will beep one (1) time when each remote control is added.
5. Turn the ignition key to OFF to exit programming mode, or cycle the ignition key OFF/ON to advance to the next Feature Bank.

To delete a remote control:

This system will store a **maximum of four (4) remote controls** in the memory. Additional programmed remote controls will delete the oldest-programmed remote control.

Deleting All Remotes:

1. Perform steps 1-3 above.
2. Press and hold the Valet/Override button for five (5) seconds.
3. The system will sound one (1) long beep. This indicates all remotes have been deleted from memory.

Notes:

- The system will store in the memory a **maximum of four (4) remote controls**. Additional programmed remote controls will delete the oldest-programmed remote control.
- The system will accept a maximum of two (2) 2-Way remote controls.
- During normal operation, the **Programmed Transmitter Notification (PTN) function** indicates how many remote controls are programmed by flashing the LED a certain number of times when the vehicle ignition is turned on.

AUX Output Controls.

AUX Output Controls are not configured during the Auto Programming sequence. This allows for customization by the installer or user. To program AUX Output Control:

1. Repeat steps 1-3 above.
2. Press the valet button to advance to the AUX Channel to be programmed. The system will beep to indicate the channel number.
3. Press the desired button or button combination selected to control the AUX output. The system will beep 1x to indicated the channel is programmed.
4. Repeat steps 2-3 until all desired AUX outputs are programmed or turn the ignition key to OFF to exit programming.

Detailed Descriptions: Setup Options

Security Control (Bank 2) [See page 23 for Programming Instruction.](#)

Feature Bank 2		Options						
		1 Chirp	2 Chirp	3 Chirp	4 Chirp	5 Chirp	6 Chirp	
Features	1	Lock / Unlock Function	500ms	3.5sec	500ms L, DBL UL	DBL L, 500ms UL	DBL L, DBL UL	500ms L, 350ms UL
	2	Ignition Lock	OFF	ON				
	3	Ignition Unlock	OFF	Unlock All	Unlock Driver			
	4	Exterior Illumination	OFF	With Arm	With Disarm	With Arm & Disarm		
	5	Auto Relock	OFF	Auto Lock Only	Auto Lock & Arm			
	6	Auto Arming / Locking	OFF	Auto Arm Only	Auto Lock & Arm			
	7	Notification Sound	Both	Siren	Horn			
	8	Horn Timing	16ms	30ms	40ms	50ms	10ms	
	9	Valet Override Method	Valet	Custom Code	Stand Alone Valet			
	10	Driver Priority Unlock	OFF	ON				
	11	Silent Choice	OFF	From Transmitter	OEM Style			
	12	Security Profile	All On	Doors off	Hood / trunk Off	All Off	All On w/ OEM RS	
	13	Door Trigger Input	Negative	Positive				
	14	Park Light / Trunk Swap	OFF	ON				
	15	Data Port Protocol	ADS	DBI				
	16	Dome Light Delay Timer	OFF / Program	15sec	30sec	45sec	60sec	120sec
	17	Alarm Trigger Legnth	30sec	45sec	60sec	90sec	120sec	

Feature 1: Lock / Unlock Function

Function: **Set the lock / unlock output timing and functionality for specific vehicle lock types.**

Setting Choices:

- **Option 1** - Lock and Unlock outputs will pulse for **500 milliseconds**.
- **Option 2** - Lock and Unlock outputs will pulse for **3.5 seconds**.
- **Option 3** - Lock output will pulse for **500ms** ; **Unlock** output will pulse twice, **500ms each**.
- **Option 4** - Lock output will **pulse twice, 500ms each** ; **Unlock** output will pulse for **500ms**.
- **Option 5** - Lock and Unlock outputs will **pulse twice for 500ms**.
- **Option 6** - Lock output will pulse for **500ms** ; **Unlock** output will pulse for **350ms**.

Feature 2: Ignition-Activated Lock

Function: **Set the door locks to lock when brake is pressed after the ignition is turned ON.**

Setting Choices:

- **Option 1** - Doors do not lock with ignition.
- **Option 2** - Doors Lock when brake is pressed after ignition on.

Feature 3: Ignition-Activated Unlock

Function: **Set the door locks to unlock when the ignition is turned off with the key.**

Setting Choices:

- **Option 1** - Doors do not unlock with ignition off.
- **Option 2** - All Doors Unlock with ignition off.
- **Option 3** - Driver Door Unlocks with ignition off.

Feature 4: Exterior Illumination

Function: **Set the parking lights and head lights to remain on for 30 seconds when the doors are locked or unlocked with the remote control.**

Setting Choices:

- **Option 1** - The lights will function **normally**.
- **Option 2** - The lights will remain on for **30 seconds when the doors are locked** with the remote control.
- **Option 3** - The lights will remain on for **30 seconds when the doors are unlocked** with the remote control.
- **Option 4** - The lights will remain on for **30 seconds when the doors are locked or unlocked** with the remote control.

Detailed Descriptions: Setup Options

Security Control (Bank 2) (cont.) [See page 23 for Programming Instruction.](#)

Feature 5: Auto ReLock Setting

Function: **Set the doors to re-lock if the system has been accidentally disarmed.**

Setting Choices:

- **Option 1** - Auto ReLock is **disabled**.
- **Option 2** - If the system has been disarmed but no doors have been opened in 3 minutes, the system will **relock the doors but not re-arm** the alarm.
- **Option 3** - If the system has been disarmed but no doors have been opened in 3 minutes, the system will **relock the doors and re-arm** the alarm.

Note: This feature is not associated with the Auto Arming / Locking.

Feature 6: Automatic Arming

Function: **Set the system to arm automatically after exiting the vehicle.**

Setting Choices:

- **Option 1** - System will **arm and doors will lock only when the alarm is armed from the remote control.**
- **Option 2** - System will **arm automatically 1 minute after the last door is closed**, and when the alarm is armed from the remote control.
- **Option 3** - System will **Arm and Lock doors automatically 1 minute after the last door is closed**, and when the alarm is armed from the remote control.

Feature 7: Notification Sounds

Function: **Set the siren and/or horn to notify when the system is armed or disarmed.**

Setting Choices:

- **Option 1** - **Siren and horn** will emit audible beeps when the system is armed and disarmed.
- **Option 2** - **Siren** will emit audible beeps when the system is armed and disarmed.
- **Option 3** - **Horn** will emit audible beeps when the system is armed and disarmed.

Note: Siren and horn will both sound if the system is triggered, regardless of this setting.

Feature 8: Horn Output Duration

Function: **Set the horn output to activate for a set time.**

Setting Choices:

- **Option 1** - Output pulses for **16 milliseconds**.
- **Option 2** - Output pulses for **30 milliseconds**.
- **Option 3** - Output pulses for **40 milliseconds**.
- **Option 4** - Output pulses for **50 milliseconds**.
- **Option 5** - Output pulses for **10 milliseconds**.

Feature 9: Valet Override Method

Function: **Set the Alarm Override Method. This will be used if the Remote is lost or inoperable.**

Setting Choices:

- **Option 1** - Alarm Override method is normal. **Ignition Key ON, press Valet button one (1) time.**
- **Option 2** - Alarm Override method is set for a **Custom Code**.
- **Option 3** - Alarm Override method is set for **Stand Alone Valet Mode**.

Note: [See Alarm Override and Custom Code Programming procedures on page 28.](#)

Detailed Descriptions: Setup Options

Security Control (Bank 2) (Cont.) [See page 23 for Programming Instruction.](#)

Feature 10: Driver Priority Unlock

Function: **Set the behavior of unlock outputs when arming and disarming the system.**

Setting Choices:

- **Option 1** - Unlock pulse will be on the **Green wire unlock output only.**
- **Option 2** - **First press** of unlock on remote will pulse **Green wire** ; **Second press within 10sec** will pulse **RED/BLACK wire.**

Feature 11: Silent Choice™

Function: **Set audible beeps on or off when arming and disarming the system.**

Setting Choices:

- **Option 1** - Pressing **Lock or Unlock at any time** will perform the function **with audible beeps.**
- **Option 2** - Pressing **Lock or Unlock for 1.5sec** on remote will control system **without an audible beep.**
- **Option 3** - **First press** of Lock or Unlock on the remote control will perform the function **without an audible beep. Second press within 10sec** will result in **audible beeps.**

Feature 12: Security Profile

Function: **Set the system to function as a keyless entry / convenience system or full-featured alarm / convenience system.**

Setting Choices:

- **Option 1** - All security, keyless entry and convenience features are **enabled.**
- **Option 2** - **Door** Trigger zone is **disabled.**
- **Option 3** - **Hood and Trunk** Trigger zones are **disabled.**
- **Option 4** - All security trigger zones are **disabled.**
- **Option 5** - All security zones are **enabled: Doors, Hood, and Trunk will be bypassed for five (5) seconds with Ignition ON ; Shock will be bypassed anytime Ignition is ON.**

Feature 13: Door Trigger Input Detection

Function: **Set the system to detect 12-Volt (+) or Ground (-) when the vehicle door is opened**

Setting Choices:

- **Option 1** - Door Trigger detection is set for **Ground (-).**
- **Option 2** - Door Trigger detection is set for **12-Volt (+).**

Feature 14: Park Light / Trunk Relay Function

Function: **Reverse the functionality of the trunk and park light outputs (i.e. when the built-in relay is needed for the trunk connection but not needed for the park light connection.)**

Setting Choices:

- **Option 1** - Functionality follows **default settings.**
- **Option 2** - The **Trunk Release Output (Dark Blue)** wire works with the Parking Lights function; the **Parking Lights Input (White/Red)** and **Parking Lights Output (White)** wires work with the trunk release function.

Feature 15: Data Bus (DBI) Port Protocol

Function: **Set functionality of the data bus connector to accept integration modules of differing protocols.**

Setting Choices:

- **Option 1** - The data bus connector will be configured to work with modules that use the **ADS Protocol.**
- **Option 2** - The data bus connector will be configured to work with modules that use the **DBI Protocol.**

Detailed Descriptions: Setup Options

Security Control (Bank 2) (Cont.) [See page 23 for Programming Instruction.](#)

Feature 16: Dome Light Delay Timer

Function: **Set the delay timer when using the vehicle's Dome Light as a door trigger.**

Setting Choices:

- **Option 1 - OFF / Delay Timer will be OFF or use the programmed time.** See page ## for dome light delay programming procedure
- **Option 2 - 15 seconds,** System will wait 15 seconds before monitoring the door trigger input.
- **Option 3 - 30 seconds,** System will wait 30 seconds before monitoring the door trigger input.
- **Option 4 - 45 seconds,** System will wait 45 seconds before monitoring the door trigger input.
- **Option 5 - 60 seconds,** System will wait 60 seconds before monitoring the door trigger input.
- **Option 6 - 120 seconds,** System will wait 120 seconds before monitoring the door trigger input.

Feature 17: Alarm Trigger Length

Function: Set the **length of time** the **Alarm Notification** will sound for each cycle.

Setting Choices:

- **Option 1 - 30 seconds,** System will Alarm Cycle will sound for 30 second.
- **Option 2 - 45 seconds,** System will Alarm Cycle will sound for 45 second.
- **Option 3 - 60 seconds,** System will Alarm Cycle will sound for 60 second.
- **Option 4 - 90 seconds,** System will Alarm Cycle will sound for 90 second.
- **Option 5 - 120 seconds,** System will Alarm Cycle will sound for 120 second.

Note: The system will check the trigger inputs between each Alarm Cycle. If the trigger input is still active the system will notify the user with another cycle.

Detailed Descriptions: Setup Options

Remote Start Control (Bank 3) [See page 23 for Programming Instruction.](#)

Feature Bank 3		Options						
		1 Chirp	2 Chirp	3 Chirp	4 chirp	5 Chirp	6 Chirp	
Features	1	Defrost Output	Pulsed	10min	RS Runtime			
	2	RS Start Notification	ON	OFF				
	3	RS Runtime	15min	20min	45min	60min	5min	10min
	4	RS Parking Lights	Steady	Flashing				
	5	Engine Confirmation	Tach	Voltage	Data	Hybrid		
	6	Voltage Level	>0.5v B4 Start	<0.5v B4 Start				
	7	Ignition 2 Output	Ignition	Accessory	Start			
	8	Ignition 3 Output	Ignition	Accessory	Start			
	9	Accessory Output	Accessory	Ignition	Start			
	10	Transmission	Auto	Manual				
	11	Max Crank Time	0.8sec	1.0sec	1.5sec	2.0sec	3.0sec	4.0sec
	12	Diesel Delay	OFF	Diesel 5	Diesel 10	Diesel 15	Diesel 20	Diesel 30
	13	Temperature Start	OFF	14F	5F	0F	-4F	-14F
	14	Crank Duration	Averaging	Preset				
	15	RS Shock Override	Shunt until Clear	Shunt RS Cycle	Shunt From TX			
	16	Turbo Timer	OFF	3min	5min	10min		
	17	Start Activation	Two Press	One Press	Three Press			
	18	RS Lock Function	No Change	UL Before L After	UL Before Start	Lock After Start		
	19	Factory Disarm Output	Single Pulse	Double Pulse	350ms	500ms	800ms	Same As Bank 2, F1
	20	Additional Unlock Pulse	No Pulse	IGN, ACC, GWR	IGN,ACC,GWR,PASD			

Feature 1: Defrost Output Duration

Function: **Set the Defrost output to activate for a set time.**

Setting Choices:

- **Option 1** - Output pulses for **1 second**.
- **Option 2** - Output stays on for **10 minutes**.
- **Option 3** - Output stays on for **the duration of the Remote Start Runtime**.

Feature 2: Remote Start Notification

Function: **Set remote start activation confirmation beeps on or off.**

Setting Choices:

- **Option 1** - On - System emits an **audible beep** when remote start is activated.
- **Option 2** - OFF -System **remains silent** when remote start is activated.

Feature 3: Remote Start Run Time

Function: **Set the maximum remote start run time if the vehicle is not entered after activation.**

Setting Choices:

- **Option 1** - Engine will run for **15 minutes**.
- **Option 2** - Engine will run for **20 minutes**.
- **Option 3** - Engine will run for **45 minutes**.
- **Option 4** - Engine will run for **60 minutes**.
- **Option 5** - Engine will run for **5 minutes**.
- **Option 6** - Engine will run for **10 minutes**.

Feature 4: Remote Start Parking Light Duration

Function: **Set parking light output to turn on or flash lights during remote start.**

Setting Choices:

- **Option 1** - Lights **remain on** during remote start.
- **Option 2** - Lights **flash** during remote start.

Detailed Descriptions: Setup Options

Remote Start Control (Bank 3) (cont.) [See page 23 for Programming Instruction.](#)

Feature 5: Engine Confirmation Mode

Function: **Determine how the system knows if remote start was successful.**

Setting Choices:

- **Option 1** - Determined by **measurement** from the **Purple/White** Tach Input wire.
- **Option 2** - Determined by the **voltage difference** before remote start and after as set in **Bank 3, Feature 6**.
- **Option 3** - Receives information through an attached **data bus interface**.
- **Option 4** - **No sensing**; assumes vehicle has started based on setting in **Bank 3, Features 11 & 14**.

Feature 6: Start Sensing Voltage Level

Function: **Set the sensitivity of voltage variance measurement to determine if the vehicle has started when Feature 5 is set to option 2, Voltage.**

Setting Choices:

- **Option 1 - High**: Voltage difference before remote start and after must be greater than .5 volts.
- **Option 2 - Low**: Voltage difference before remote start and after must be less than .5 volts.

Feature 7: Ignition 2 Output Function (Green)

Function: **Set the functionality of the programmable Ignition 2 output.**

Setting Choices:

- **Option 1** - Wire sends 12-Volt (+) during ignition **and start**.
- **Option 2** - Wire sends 12-Volt (+) during ignition; **drops out during start**.
- **Option 3** - Wire sends 12-Volt (+) during start **only**.

Feature 8: Ignition 3 Output Function (Pink)

Function: **Set the functionality of the programmable Ignition 3 output.**

Setting Choices:

- **Option 1** - Wire sends 12-Volt (+) during ignition **and start**.
- **Option 2** - Wire sends 12-Volt (+) during ignition; **drops out during start**.
- **Option 3** - Wire sends 12-Volt (+) during start **only**.

Feature 9: Accessory Output Function (Purple)

Function: **Set the functionality of the programmable Accessory output.**

Setting Choices:

- **Option 1** - Wire sends 12-Volt (+) during ignition; **drops out during start**.
- **Option 2** - Wire sends 12-Volt (+) during ignition **and start**.
- **Option 3** - Wire sends 12-Volt (+) during start **only**.

Feature 10: Transmission Type

Function: **Set the functionality of the remote start system based on the vehicle transmission type.**

Setting Choices:

- **Option 1** - System is set for **Automatic** transmission.
- **Option 2** - System is set for **Manual** Transmission (**Note**: Remote Start Ready Mode must be set by the driver before exiting the vehicle.)

Feature 11: Maximum Crank Time

Function: **Set maximum crank time for all remote start settings.**

Setting Choices:

- **Option 1** - Starter will crank for **.8 seconds**.
- **Option 2** - Starter will crank for **1 second**.
- **Option 3** - Starter will crank for **1.5 seconds**.
- **Option 4** - Starter will crank for **2 seconds**.
- **Option 5** - Starter will crank for **4 seconds**.

Detailed Descriptions: Setup Options

Remote Start Control (Bank 3) (cont.) [See page 23 for Programming Instruction.](#)

Feature 12: Diesel (Pre-Start) Delay

Function: **After remote start ignition is activated, set delay of crank to accommodate diesel engines.**

Setting Choices:

- **Option 1** - Vehicle starts **immediately** after remote start ignition.
- **Option 2** - Start is delayed for **5 seconds** after remote start ignition.
- **Option 3** - Start is delayed for **10 seconds** after remote start ignition.
- **Option 4** - Start is delayed for **15 seconds** after remote start ignition.
- **Option 5** - Start is delayed for **20 seconds** after remote start ignition.
- **Option 6** - Start is delayed for **30 seconds** after remote start ignition.

Feature 13: Temperature-Based Start Setting

Function: **Set the outside temperature that will automatically trigger the start function.**

Setting Choices:

- **Option 1** - Temperature-based start is **inactive**.
- **Option 2** - Vehicle will start when temperature drops below **14 ° F**.
- **Option 3** - Vehicle will start when temperature drops below **5 ° F**.
- **Option 4** - Vehicle will start when temperature drops below **0 ° F**.
- **Option 5** - Vehicle will start when temperature drops below **-4 ° F**.
- **Option 6** - Vehicle will start when temperature drops below **-14 ° F**.

Note: Requires Activation with Remote.

Feature 14: Crank Duration

Function: **Set how the system will determine how long to crank the starter.**

Setting Choices:

- **Option 1** - Starter will crank based on **average of last 8 times** the vehicle was started with the key.
- **Option 2** - Starter will crank for **maximum time** as set in **Bank 3, Feature 11**.

Feature 15: Remote Start Shock Sensor Override

Function: **Set Shock Sensor Operation with Remote Start.**

Setting Choices:

- **Option 1** - Shock Sensor will turn off when remote start is engaged and will turn on if no vibration is detected after the engine is running.
- **Option 2** - Shock sensor will turn off for the duration of the Remote Start Runtime
- **Option 3** - Shock sensor will turn off if Lock is pressed while vehicle is remote started.

Feature 16: Turbo Timer Setting

Function: **Set the time that the engine remains running after the vehicle is turned off with the key.**

Setting Choices:

- **Option 1** - Turbo timer function is **inactive**.
- **Option 2** - Vehicle will remain running for **3 minute**.
- **Option 3** - Vehicle will remain running for **5 minutes**.
- **Option 4** - Vehicle will remain running for **10 minutes**.

Detailed Descriptions: Setup Options

Remote Start Control (Bank 3) (Cont.) [See page 23 for Programming Instruction.](#)

Feature 17: Remote Start Activation

Function: **Set remote start to activate with one, two, or three presses from the remote control or pulses detected on the Dark Blue/Black External Activation Input.**

Setting Choices:

- **Option 1** - Press the Start button two **(2) times** for remote start.
- **Option 2** - Press the Start button one **(1) time** for remote start.
- **Option 2** - Press the Start button three **(3) times** for remote start.

Note: Does not apply to 1 Button Transmitters.

Feature 18: Remote Start Lock Control

Function: **If desired, set door lock outputs to function before or after remote start.**

Setting Choices:

- **Option 1** - Remote Start Lock Control is **inactive**.
- **Option 2** - Doors will **unlock before remote start; lock after remote start**.
- **Option 3** - Doors will **unlock before remote start**.
- **Option 4** - Doors will **lock after remote start**.

Feature 19: Factory Disarm Output Function (BLACK/BLUE)

Function: **Set the functionality of the programmable output.**

Setting Choices:

- **Option 1** - Sends a **1-second pulse** before start and during Unlock.
- **Option 2** - Sends a **350ms pulse** before start and during Unlock
- **Option 3** - Sends a **500ms pulse** before start and during Unlock
- **Option 4** - Sends a **800ms pulse** before start and during Unlock
- **Option 5** - Sends a pulse **before start** and **during unlock** based on setting of **Bank 2, Feature 1**.

Feature 20: Additional Unlock Pulses

Function: **Set other outputs to pulse when the vehicle is unlocked with the remote control.**

Setting Choices:

- **Option 1** - **No** additional unlock pulses.
- **Option 2** - Pulse **Ignition, Accessory and Ground While Running** wires upon Unlock.
- **Option 3** - Pulse **Ignition, Accessory, Ground While Running, and Pulse After Shutdown** wires upon unlock.

Detailed Descriptions: Setup Options

Negative Output Control (NOC)

Negative Output Control (NOC) allows the installer to program any NOC output for any NOC option. For example, if an installer is not using the GREEN/WHITE Dome Light output, but requires a second Remote Start Status Output, the system can be programmed to change the output type. Once programmed in the NOC Menu, the GREEN/WHITE wire will operate with the same function as the LIGHT BLUE (Remote Start Status).

Note: This can only be programmed using the FlashLogic Weblink or Weblink Mobile.

Lock	Ground While Armed
Unlock	Ground While Disarmed
2nd Unlock	Domelight
Trunk	Headlight
Remote Start Status	Defrost
Ignition	LED
Accessory	Ch. 4 AUX
Pulse During Crank	Ch. 5 AUX
Pulse After Shutdown	Ch. 6 AUX
Factory Arm	Ch. 7 AUX
Factory Disarm	

Door Lock

This option supplies a pulse when the Lock function is activated from the remote control or system.

Door Unlock

This option supplies a pulse when the Unlock function is activated from the remote control or system.

2nd Door Unlock

This option supplies a pulse when the Unlock function is activated from the remote control or system (2) two times within 10 seconds. [This requires Feature Bank 2, Feature 10 to be programmed ON.](#)

Trunk Release

This option supplies a pulse when the trunk function is activated from the remote control or system

Remote Start Status

This output supplies an output for the entire remote start runtime programmed in Feature Bank 3. This output will activate before the Ignition output and remain on for 4sec after shutdown.

Ignition

This option will supply an output for the entire remote start runtime programmed in Feature Bank 3. This output will turn on after Remote Start Status and remains on during engine crank. This output will turn off with shutdown.

Accessory

This option will supply an output for the entire remote start runtime programmed in Feature Bank 3. This output will turn on after Remote Start Status and will turn off during engine crank. This output will turn off with shutdown.

Factory Arm

This option supplies an output after remote start and with the lock function from the remote control or system.

Factory Disarm

This option supplies output before remote start and when the unlock function is activated from the remote control or system.

Detailed Descriptions: Setup Options

Negative Output Control (NOC) (CONT.)

Pulse During Crank

This option supplies a pulse to crank the engine's starter. This output will pulse for the timing option selected in Feature Bank 3, Feature 11.

Pulse After Shutdown

This option supplies a pulse after remote start shutdown only.

Domelight

This option will supply an output for 30 seconds with the unlock function from the remote control or system.

Headlight

This option will supply an output for 30 seconds with the option selected in Feature Bank 2, Feature 4.

Defrost

This option will supply an output for the option selected in Feature Bank 3, Feature 1.

LED

This option will supply a pulsed output when the alarm is armed.

Ch. 4 AUX

This option will supply an output when the AUX 1 function is pressed on the remote control or CarLink system. See page 18 for AUX Output Options.

Ch. 5 AUX

This option will supply an output when the AUX 2 function is pressed on the remote control or CarLink system. See page 18 for AUX Output Options.

Ch. 6 AUX

This option will supply an output when the AUX 3 function is pressed on the remote control or CarLink system. See page 18 for AUX Output Options.

Ch. 7 AUX

This option will supply an output when the AUX 4 function is pressed on the remote control or CarLink system. See page 18 for AUX Output Options.

Ground While Armed (GWA)

This option will supply an output when the Alarm System is Armed.

Ground While Disarmed (GWD)

This option will supply an output when the Alarm System is Disarmed.

Detailed Descriptions: Setup Options

Auxiliary Output Control (AUX Control)

Auxiliary (AUX) output control allows each AUX Channel output to be customized to the user or vehicle's need. See the list below for a detailed description of the available options. AUX Ch. Outputs can only be programmed using the FlashLogic Weblink or Weblink Mobile.

1 Second Pulse	30 Second Pulse
5 Second Pulse	Push & Hold
10 Second Pulse	Latch ON/OFF
15 Second Pulse	Latch 10min
20 Second Pulse	Latch Runtime

1 Second Pulse

This option supplies a one (1) second pulse each time the AUX Ch. is activated from the remote or CarLink System.

5 Second Pulse

This option supplies a five (5) second pulse each time the AUX Ch. is activated from the remote or CarLink System.

10 Second Pulse

This option supplies a ten (10) second pulse each time the AUX Ch. is activated from the remote or CarLink System.

15 Second Pulse

This option supplies a fifteen (15) second pulse each time the AUX Ch. is activated from the remote or CarLink System.

20 Second Pulse

This option supplies a twenty (20) second pulse each time the AUX Ch. is activated from the remote or CarLink System.

30 Second Pulse

This option supplies a thirty (30) second pulse each time the AUX Ch. is activated from the remote or CarLink System.

Push & Hold

This option will supply an output when the remote button is pressed by the user and will remain on until the user releases the remote button.

Latch ON/OFF

This option will supply an output when the AUX Channel is activated from the remote control or CarLink system and remain on until the AUX Channel is activated again.

Latch 10min

This option will supply an output when the AUX Channel is activated from the remote control or CarLink system and remain on for ten (10) minutes.

Runtime Latch

This option will supply an output when the remote start is activated and remain on for the runtime selected on Feature Bank 3, Feature 3.

Detailed Descriptions: Setup Options

Programmable Input Control (PIC Control)

Programmable Input Control (PIC) allows each PIC input to be customized to the user or vehicle's need. See the list below for a detailed description of the available options. PIC Inputs can only be programmed using the FlashLogic Weblink or Weblink Mobile.

Door Trigger	Full Shock Trigger
Trunk Trigger	Parking Brake
Hood Trigger	Brake
N.C. Door Trigger	External Start Activation
Pre-Warn Shock Trigger	Diesel Glow Plug

Door Trigger Input

This option will be used for all Door trigger functions including Alarm Trigger. If using an LCD RF kit this input will display the Door icon when the Alarm is triggered.

Trunk Trigger Input

This option will be used for all Trunk trigger functions including Alarm trigger. If using an LCD RF kit this input will display the Trunk icon when the Alarm is triggered.

Hood Trigger Input

This option will be used for all Hood trigger functions including Alarm trigger. If using an LCD RF kit this input will display the Hood icon when the Alarm is triggered.

Normally Closed Door Trigger Input

This option will be used in vehicles with a Normally Closed Door Trigger. This type of circuit will be show Ground (-) or Positive (+) when the vehicle door is closed then switch to an Open Circuit when the door is open. If using an LCD RF kit this input will display the Door icon when the Alarm is triggered.

Pre-Warn Shock Trigger Input

This option will be used to add additional security sensors to the alarm system. When this input is detected the system will beep four (4) times quickly to warn away any potential thief. If using an LCD or LED RF kit this input will not provide a warning when the Pre-Warn input is detected.

Full Shock Trigger Input

This option will be used to add additional security sensors to the alarm system. When this input is detected the system will trigger a full alarm cycle. If using an LCD RF kit this input will display the Shock icon when the alarm is triggered

Parking Brake Input

This option will be used for all Parking Brake functions such as Turbo Timer and Manual Transmission Ready Mode.

Brake Input

This option will be used for all Brake functions such as Remote Start and Alarm trigger. If using an LCD or LED RF kit this input will provide a warning when the Alarm is triggered.

External Start Activation Input

This option will be used to activate or deactivate the Remote Start. This input is configurable using Feature Bank 3, Feature 17.

Diesel Wait to Start Input

This option will be used to control the Diesel Wait to Start function. This input is configurable using Feature Bank 3, Feature 17. When this input is detected, the system will wait until the input is cleared before cranking the vehicle's starter. Diesel Wait to Start mode must be activated in Feature Bank 3, Feature 12.

Detailed Descriptions: System Operation

Manual Transmission Mode (Ready Mode)

This remote start system is compatible with manual transmission vehicles. When Manual Transmission Mode is activated in Feature Bank 3, Feature 10, this system will monitor multiple inputs to safely and securely remote start the vehicle.

Note: A connection to the vehicle's parking brake and tach signal (Analog or Data) is required.

Ready Mode

When manual transmission mode is programmed on, the system will require the user to enter Manual Transmission Ready Mode. Ready Mode is a procedure that will keep the vehicle's engine running while the user exits the vehicle to ensure the vehicle is in Neutral.

To activate Ready Mode:

1. With the vehicle's engine running; Set the parking brake to ON.
2. Release the vehicle's foot brake.
3. Activate the Pursuit remote start by pressing the Start button on the remote control or Carlink App. The vehicle parking lights will illuminate to indicate the remote start is activated. If you are using a 2-Way remote, the remote will beep four (4) times.
4. Without pressing the brake, set the ignition key to OFF and exit the vehicle. The engine will remain running.
5. After exiting the vehicle, close all doors then press Lock on the remote control or Carlink App. The engine will shut down and the system will sound two (2) short beeps followed by one (1) long beep to indicate Ready Mode is activated. The vehicle will now remote start when activated.

What can cancel Ready Mode?

Ready mode will be canceled if the system detects any of the following:

- Open trigger zone (Doors, Hood, or Trunk).
- Ignition ON.
- Parking Brake OFF.

If ready mode is canceled the vehicle will not remote start. The user must repeat Steps 1-5 above to activate Ready Mode.

Easy Entry Mode

Easy Entry Mode allows the user to gain access to the vehicle without canceling Ready Mode. This can be used to retrieve forgotten item or to configure the climate controls for the next remote start cycle.

To use Easy Entry Mode:

1. Remote start the vehicle using the remote control.
2. Enter the vehicle.
3. When ready, Exit the vehicle and close all doors.
4. Press Lock on the remote control. The engine will shut down and the system will sound two (2) short beeps followed by one (1) long beep to indicate Ready Mode is activated.

Manual Transmission Pit Stop Mode

Manual Transmission Pit Stop Mode allows the user to activate the remote start and exit the vehicle with the key. When activated the system will keep the vehicle engine running for the runtime selected in Feature Bank 3, Feature 3.

To use Manual Transmission Pit Stop Mode:

1. With the vehicle's engine running; Set the parking brake to ON.
2. Release the vehicle foot brake.
3. Activate the remote start by pressing the Start button on the remote control. The vehicle parking lights will illuminate to indicate the remote start is activated. If you are using a 2-Way remote, the remote will beep four (4) times.
4. Without pressing the brake, set the ignition key to OFF and exit the vehicle. The engine will remain running.
5. After exiting the vehicle, close all doors then press Lock button then Start button on remote control. The system will lock all doors and remain running for the programmed remote start runtime.

Detailed Descriptions: System Operation

Remote Control Operation

This system is compatible with multiple different remote configurations; one (1) button, five (5) button, and LCD remotes. The matrix below describes how each remote offering will control the basic system functions. See Owner's Guide for more detailed information



One (1) Button Remotes (1-Way & 2-Way)

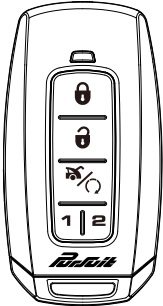

Button	Action	Function
	Press 1x	Lock
	Press 2x	Unlock
	Hold 3 Seconds	Start

Five Button Remotes (1-Way & 2-Way LED)



Button	Action	Function
	Press 1x	Lock
	Hold 3 Seconds	Panic ON/OFF
	Press 1x	Unlock
	Hold 3 Seconds	Panic ON/OFF
	Press 2x	Start (Programmable)
	Hold 3 Seconds	Trunk Release
1	Press 1x	Programmable AUX
	Press & Hold	
2	Press 1x	Programmable AUX
	Press & Hold	

Quick Reference: System Programming

Programming Mode Entry and Exit Procedure

Once the system is installed and powered up, you will use the vehicle ignition, override button and a programmed remote control to set all system options. Feature options are divided into categories, or **Banks**, as described throughout this section. **Ensure that at least one remote control is programmed** to the system. If not, or if you need to program more remote controls, use the diagram steps to access **Bank 1**.

The siren and LED will indicate your status and selections. Follow the diagram below to enter and maneuver through the programming procedure.

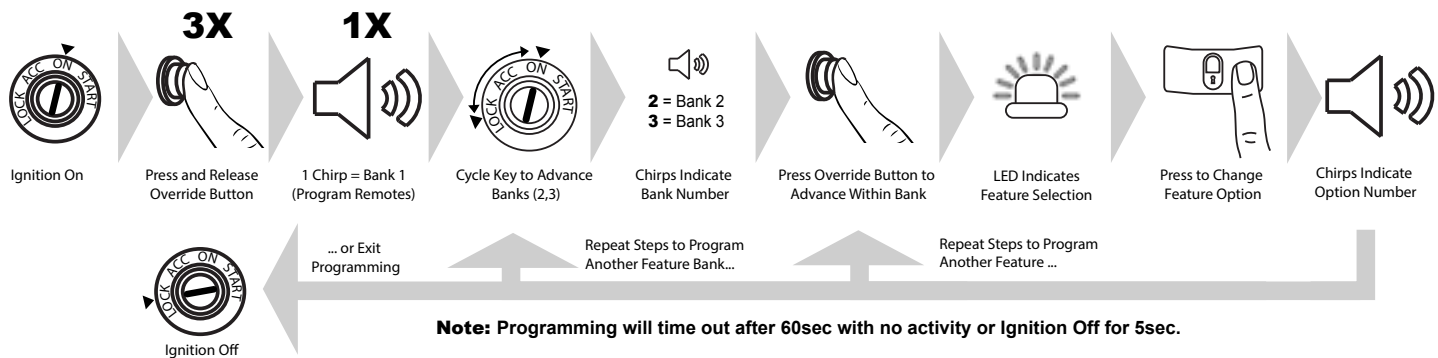

1. Turn the ignition ON.
2. Press and release the valet/override button three (3) times.
3. The system will beep one (1) time, indicating you have accessed Bank 1.
4. Each cycle of the Ignition, OFF/ON, will advance to the next bank (up to Bank 3) then restart at Bank 2. (Note: To re-access Bank 1 for transmitter programming, you will need to exit and re-enter programming mode.)
5. The system will beep a number of times to indicate the Bank number:
 - 1 beeps: [Bank 1 - Programming Remote Controls](#)
 - 2 beeps: [Bank 2 - Security Control Options](#)
 - 3 beeps: [Bank 3 - Remote Start Control Options](#)
6. Once you have accessed the desired bank, press the valet/override button to advance through the features. The LED will flash a number of times to indicate the feature, based on the charts that follow this section. The system will chirp a number of times to indicate the Option programmed.
7. Once you have accessed the desired feature, press the LOCK button on the remote control to advance through the feature's setting options. The system will beep a number of times to indicate the Option setting, based on the charts that follow this section.
8. Once you have made the desired setting, you can press the valet/override button to advance through the features within the bank, or cycle the Ignition key OFF/ON to advance to the next bank.
9. Once you have completed programming, **you MUST turn the ignition key to OFF** to exit the programming mode. Programming will automatically exit after sixty (60) seconds of inactivity.

Quick Reference: Setup Options

Bank 1: Transmitter Programming Options [See page 8 for a detailed description.](#)

Feature Bank 1		Description	
Channel	1	Auto Program/Lock	Press Lock button on remote
	2	Unlock	Press Unlock button on remote
	3	Trunk/Start	Press Trunk/Start button on remote
	4	Ch. 4 AUX	Press button/buttons to control AUX Ch. 4
	5	Ch. 5 AUX	Press button/buttons to control AUX Ch. 5
	6	Ch. 6 AUX	Press button/buttons to control AUX Ch. 6
	7	Ch. 7 AUX	Press button/buttons to control AUX Ch. 7

Bank 2: Security Options [See pages 9-12 for detailed descriptions.](#)

Feature Bank 2		Options						
		1 Chirp	2 Chirp	3 Chirp	4 Chirp	5 Chirp	6 Chirp	
Features	1	Lock / Unlock Function	500ms	3.5sec	500ms L, DBL UL	DBL L, 500ms UL	DBL L, DBL UL	500ms L, 350ms UL
	2	Ignition Lock	OFF	ON				
	3	Ignition Unlock	OFF	Unlock All	Unlock Driver			
	4	Exterior Illumination	OFF	With Arm	With Disarm	With Arm & Disarm		
	5	Auto Relock	OFF	Auto Lock Only	Auto Lock & Arm			
	6	Auto Arming / Locking	OFF	Auto Arm Only	Auto Lock & Arm			
	7	Notification Sound	Both	Siren	Horn			
	8	Horn Timing	16ms	30ms	40ms	50ms	10ms	
	9	Valet Override Method	Valet	Custom Code	Stand Alone Valet			
	10	Driver Priority Unlock	OFF	ON				
	11	Silent Choice	OFF	From Transmitter	OEM Style			
	12	Security Profile	All On	Doors off	Hood / trunk Off	All Off	All On w/ OEM RS	
	13	Door Trigger Input	Negative	Positive				
	14	Park Light / Trunk Swap	OFF	ON				
	15	Data Port Protocol	ADS	DBI				
	16	Dome Light Delay Timer	OFF / Program	15sec	30sec	45sec	60sec	120sec
	17	Alarm Trigger Legnth	30sec	45sec	60sec	90sec	120sec	

Bank 3: Remote Start Options [See pages 13-16 for detailed descriptions.](#)

Feature Bank 3		Options						
		1 Chirp	2 Chirp	3 Chirp	4 chirp	5 Chirp	6 Chirp	
Features	1	Defrost Output	Pulsed	10min	RS Runtime			
	2	RS Start Notification	ON	OFF				
	3	RS Runtime	15min	20min	45min	60min	5min	10min
	4	RS Parking Lights	Steady	Flashing				
	5	Engine Confirmation	Tach	Voltage	Data	Hybrid		
	6	Voltage Level	>0.5v B4 Start	<0.5v B4 Start				
	7	Ignition 2 Output	Ignition	Accessory	Start			
	8	Ignition 3 Output	Ignition	Accessory	Start			
	9	Accessory Output	Accessory	Ignition	Start			
	10	Transmission	Auto	Manual				
	11	Max Crank Time	0.8sec	1.0sec	1.5sec	2.0sec	3.0sec	4.0sec
	12	Diesel Delay	OFF	Diesel 5	Diesel 10	Diesel 15	Diesel 20	Diesel 30
	13	Temperature Start	OFF	14F	5F	0F	-4F	-14F
	14	Crank Duration	Averaging	Preset				
	15	RS Shock Override	Shunt until Clear	Shunt RS Cycle	Shunt From TX			
	16	Turbo Timer	OFF	3min	5min	10min		
	17	Start Activation	Two Press	One Press	Three Press			
	18	RS Lock Function	No Change	UL Before L After	UL Before Start	Lock After Start		
	19	Factory Disarm Output	Single Pulse	Double Pulse	350ms	500ms	800ms	Same As Bank 2, F1
	20	Additional Unlock Pulse	No Pulse	IGN, ACC, GWR	IGN,ACC,GWR,PASD			

Quick Reference: Programming & Diagnostics

Data Port Protocol Selection

The default data port protocol of this model is ADS (iDatalink 2-Way). This model is capable of detecting the correct data port protocol (ADS or DBI) and automatically configuring Feature Bank 2; Feature 18. To initialize the detection procedure:

1. Press and hold the valet button.
2. Cycle the vehicle's Ignition ON/OFF two (2) times.
3. Release the valet button.

Note: This feature is only available on module firmware v2.0 or higher.

Tach Function

When using the GREEN/ORANGE tach wire, the vehicle tach rate must be programmed.

Programming with valet button when tach wire is connected:

1. Turn the ignition key to the ON position.
2. Press and release the valet/override button three (3) times.
3. Immediately turn the ignition key OFF.
4. Press and hold the valet/override button, then start the vehicle using the key.
5. When the unit senses the tach signal, the parking lights will begin to flash.
6. Allow the vehicle to settle to a normal idle speed.
7. Release the valet/program push-button switch.

The parking lights will turn on for two (2) seconds and one (1) long chip will indicate that the learned tach signal is stored and the unit has exited tach learn mode.

Programming without valet button when tach wire is connected:

1. Turn the ignition key to the ON position and start the vehicle's engine.
2. Wait for Engine RPM to lower to a normal idle.
3. Press and hold the vehicle's brake pedal.
4. Press the LOCK button on the OEM remote or the Carlink App.

The vehicle's parking lights will flash seven (7) times to indicate the tach signal has been learned. If the parking lights do not flash, locate another tach source and repeat steps 1 - 4 above.

Note: Programming tach signal via OEM or Telematics control is only available on Firmware v1.47 or Higher.

Dome Light Delay

To program the Pursuit system to wait until the dome light turns off before arming:

1. Close all doors.
2. With the vehicle ignition off, press LOCK, UNLOCK, LOCK, UNLOCK, LOCK, UNLOCK, LOCK on the remote control. The dash-mounted LED will turn on.
2. Immediately OPEN then CLOSE the door WITHOUT disarming the system. After the dome light turns off, the LED will flash to indicate programming completion.
3. Disarm and exit the vehicle.

To return the system to default dome light sensing:

1. Turn the vehicle ignition ON then OFF three (3) times, then press and hold the valet button for five (5) seconds.
2. The system will beep one (1) time indicating the learned delay has been cleared.

Quick Reference: Programming & Diagnostics

2 /4 Hour Timed Start

This module has the ability to start the vehicle automatically at timed intervals. This feature can be useful in extremely cold climates where starting the engine is the only means to keep the battery charged and fluids warm. The factory preset start time is four (4) hours.

To select between two (2) and four (4) hour timers:

1. Press and hold the valet button.
2. Cycle the vehicle's Ignition ON/OFF one (1) time.
3. Release the valet button.
4. Within ten (10) seconds, press and release the valet button two (2) or four (4) times.

The vehicle's parking lights will flash two (2) or four (4) times to indicate the timer selection.

To activate two (2) and four (4) hour timer:

1. Cycle the vehicle's Ignition ON/OFF one (1) time.
2. Within ten (10) seconds, press and release the Start button on the remote control four (4) times.

The vehicle's parking lights will flash four (4) times to indicate the timer is activated. The vehicle will automatically start every two (2) or four (4) hours as programmed for a maximum of forty-eight (48) hours. To cancel 2/4 hour timer mode, start the vehicle using the remote control or the vehicle's Ignition key.

Turbo Timer

This model is equipped with a Turbo Timer. This feature will automatically engage the remote start to keep the vehicle's engine running. This will allow for the engine to properly cool down and circulate fluids through the vehicle's Turbo Charger. The Turbo Timer duration must be selected in Feature Bank 3 before it can be activated by the user.

To activate the Turbo Timer:

1. Start with the vehicle's engine running for at least fifteen (15) seconds.
2. Apply the vehicle's Parking Brake.
3. Press and release the valet button two (2) times. The vehicle's parking lights will flash two (2) times for confirmation.
4. Release and apply the vehicle's parking brake.

To use the Turn Timer feature:

1. With the engine running, activate the vehicle's Parking Brake.
2. Release the vehicle's brake pedal.

To cancel the Turbo Timer feature, press and release the vehicle's brake pedal or use the Start function on the remote control. To prevent the Turbo Timer feature from engaging, press and hold the brake pedal while setting the vehicle's Ignition to the OFF position.

Silent Arm and Disarm

Program the Pursuit system to arm and disarm without notification beeps. (The siren will sound if the system is triggered while armed.)

1. Turn the ignition ON then OFF.
2. Press and release the valet/programming button three (3) times. The system will respond with one (1) beep for ON or two (2) beeps for OFF.

Quick Reference: Programming & Diagnostics

User Selectable LED

This feature will control whether the LED is ON or OFF when the system is Armed/Locked. This will be selectable in feature programming OR on-the-fly without entering the programming feature banks.

1. Turn the ignition ON, OFF, ON, OFF.
2. Press and hold valet button for five (5) seconds.

The LED will flash one (1) time for ON, two (2) times for OFF. This feature will not affect LED flash during programming.

Adjusting the Shock Sensor

1. Arm the system, wait 5-10 seconds, then with an open palm carefully apply impact to areas of the vehicle to test the shock sensor's sensitivity.
2. To adjust, turn the adjustment knob on the shock sensor counter-clockwise for less sensitivity; clockwise for more sensitivity.
3. If the proper sensitivity still cannot be achieved, re-locate the shock sensor.

Troubleshooting Trigger Zones

Test the doors, hood, trunk, and shock sensor to ensure they trigger the security system. Once triggered, the LED flashes to indicate the trigger source:

1	Shock
2	Trunk / Hood
3	Door

Troubleshooting Remote Start

All Pursuit remote start system will provide parking light feedback to display remote start errors or shutdowns. The vehicle parking lights will flash to display error or shutdown code.

1	Runtime Expired
2	Remote Shutdown
3	Brake On
4	Manual Mode
5	Hood Open
6	Low / No Tach
7	Tach Programming
8	High Tach

Quick Reference: Alarm Override Procedures

Valet Alarm Override

The Valet Override procedure will disable the alarm when the remote is not available or has become inoperative. If the vehicle door is opened without disarming, the alarm will sound and the vehicle will not start when attempting to start with the key. To disable the alarm:

1. Turn the vehicle ignition to ON.
2. Within five (5) seconds, press and release valet button on Antenna one (1) time.

The alarm will silence and the vehicle will now start normally with the key.

Custom Code Override

Unlike the default Valet Override, Custom Code Override is a user personalized code that offers a higher level of security. If the user chooses to use Custom Code Override, Feature Bank 2 ; Feature 9 must be programmed for "Custom Code". Once the option has been selected the code must be programmed. Once the Custom Code is programmed it cannot be changed without first disarming the alarm.

Custom Code Override Procedure

The Custom Code is made up of 2 numbers. Each chosen number must be between digits 1-9. The default Custom Code is "11". To disarm the alarm using the Custom Code option:

1. Turn the vehicle ignition to ON.
2. Within five (5) seconds, Press the valet button one (1) time.
3. Within five (5) seconds, Turn the ignition OFF/ON.
4. Within five (5) seconds, Press the valet button one (1) time.
5. Turn the vehicle ignition to OFF then ON to start the vehicle.

Custom Code Programming Procedure

In this example, the user has selected Custom Code "23". To program a user selected custom code start with the alarm disarmed:

1. Turn the ignition to the ON position
2. Within ten (10) seconds, press the valet button three (3) times to enter programming.
3. Within ten (10) seconds, Cycle the ignition OFF/ON, OFF/ON, OFF/ON. The system will beep one (1) time.
4. Within ten (10) seconds, Press the valet button two (2) times. This number will indicate the first digit of the chosen Custom Code.
5. Within ten (10) seconds, Cycle the ignition OFF/ON.
6. Within ten (10) seconds, Press the valet button three (3) times. This number will indicate the second digit of the chosen Custom Code.
7. Cycle the ignition OFF.

If the Custom Code was accepted the LED will flash the first number (2), pause, then the second number (3). This will repeat two (2) more times to confirm the Custom Code entry. If after 15sec the LED does not flash please repeat steps 1-7.

Stand Alone Override

Stand Alone Valet Override is an option available to override the alarm without the use of the valet button. This requires Feature Bank 2, Feature 9 to be programmed for "Stand Alone Valet". Once programmed, to disarm the alarm without the use of the remote or valet button:

1. Within five (5) seconds, Cycle the ignition ON, OFF, ON.
2. Within five (5) seconds, Press brake pedal three (3) times.

Quick Reference: Wiring Diagrams

Door Lock Connections

Negative-Trigger Door Locks

Verification: The vehicle wires register Ground when the Lock and Unlock switches are activated.

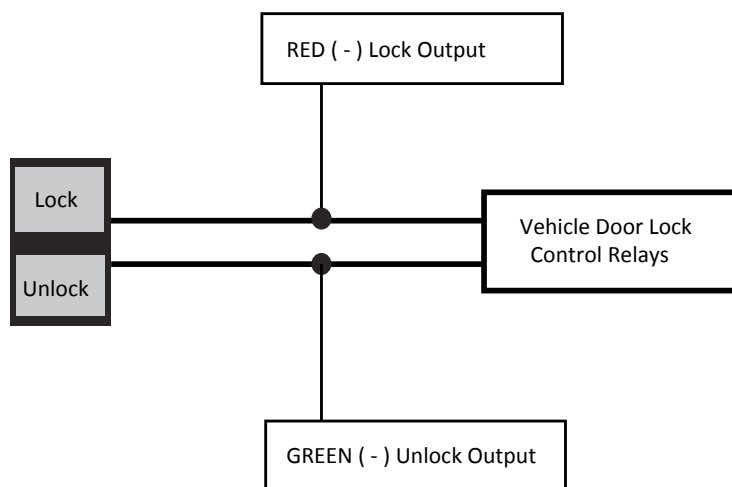

Positive-Trigger Door Locks

Verification: The vehicle wires register 12V+ when the Lock and Unlock switches are activated.

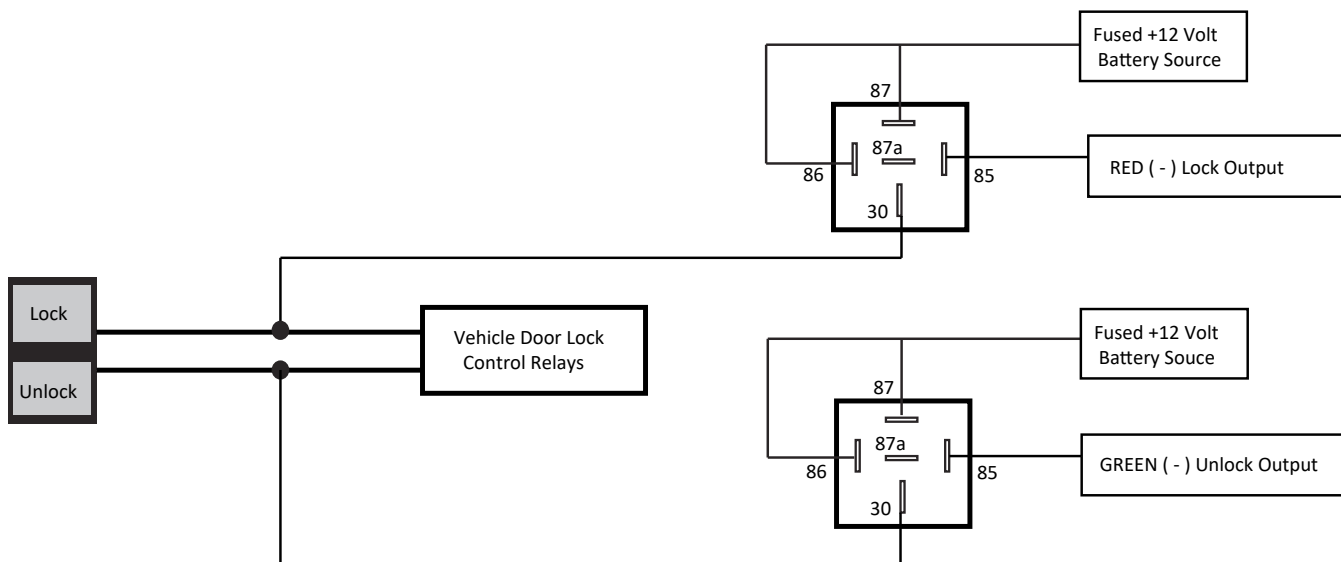

Quick Reference: Wiring Diagrams

Door Lock Connections

Single-Wire Negative Multiplex Door Locks (Relays required)

Verification: The vehicle wire registers variable Ground values when the Lock and Unlock switches are activated. Please consult the vehicle-specific wire and location chart for resistor values.

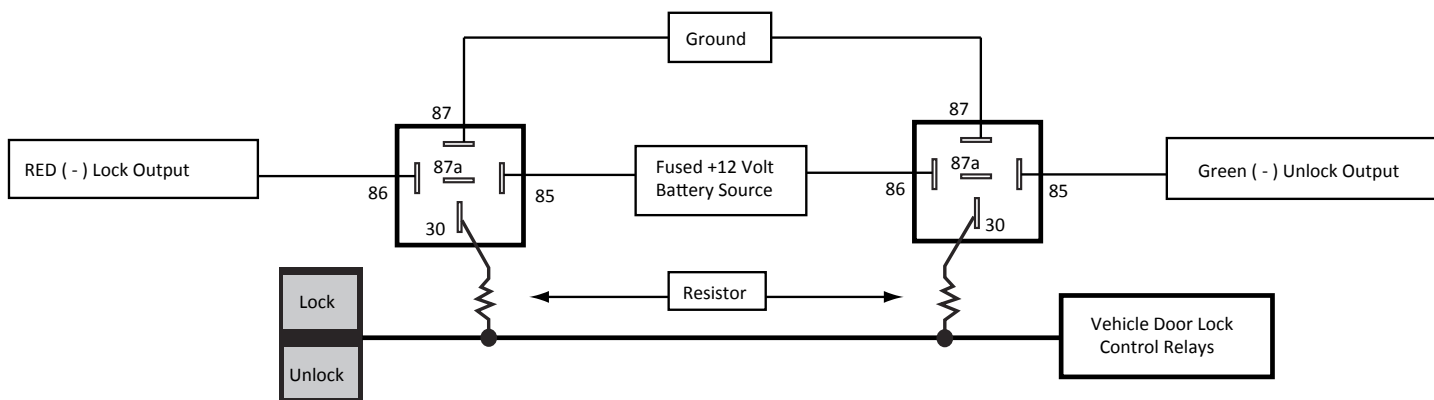

Single-Wire Positive Multiplex Door Locks (Relays required)

Verification: The vehicle wire registers variable 12V+ values when the Lock and Unlock switches are activated. Please consult the vehicle-specific wire and location chart for resistor values.

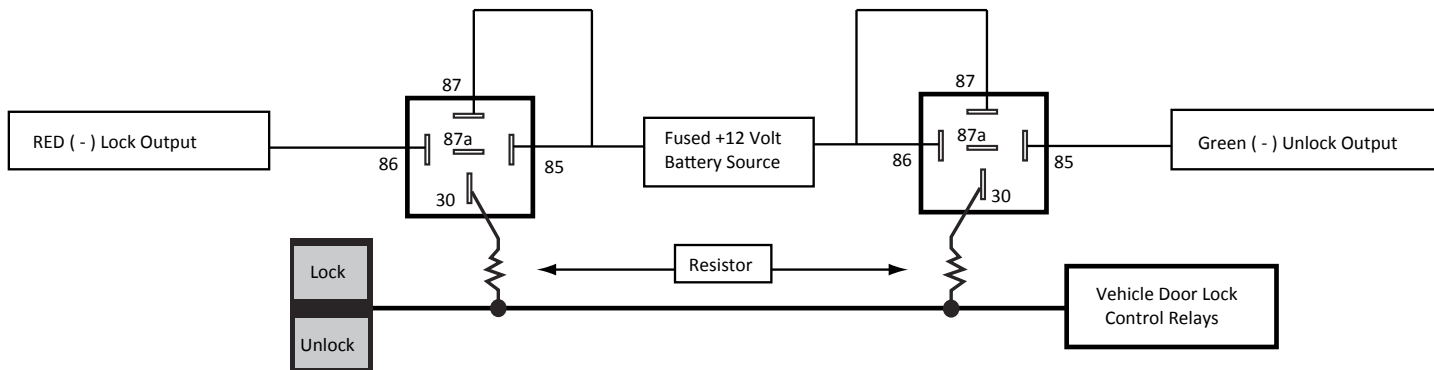

Quick Reference: Wiring Diagrams

Door Lock Connections

Reverse-Polarity Door Locks (Relays required)

Verification: The vehicle wires rest at Ground and register 12V+ when the Lock and Unlock switches are activated.

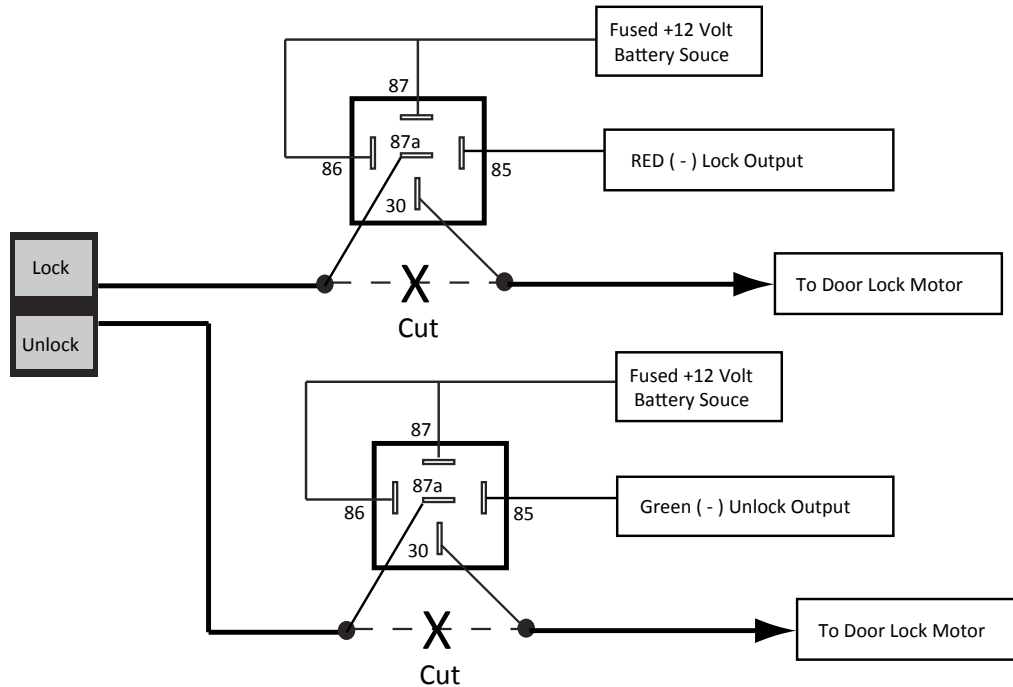

Aftermarket Actuators (Relays and door lock actuators required)

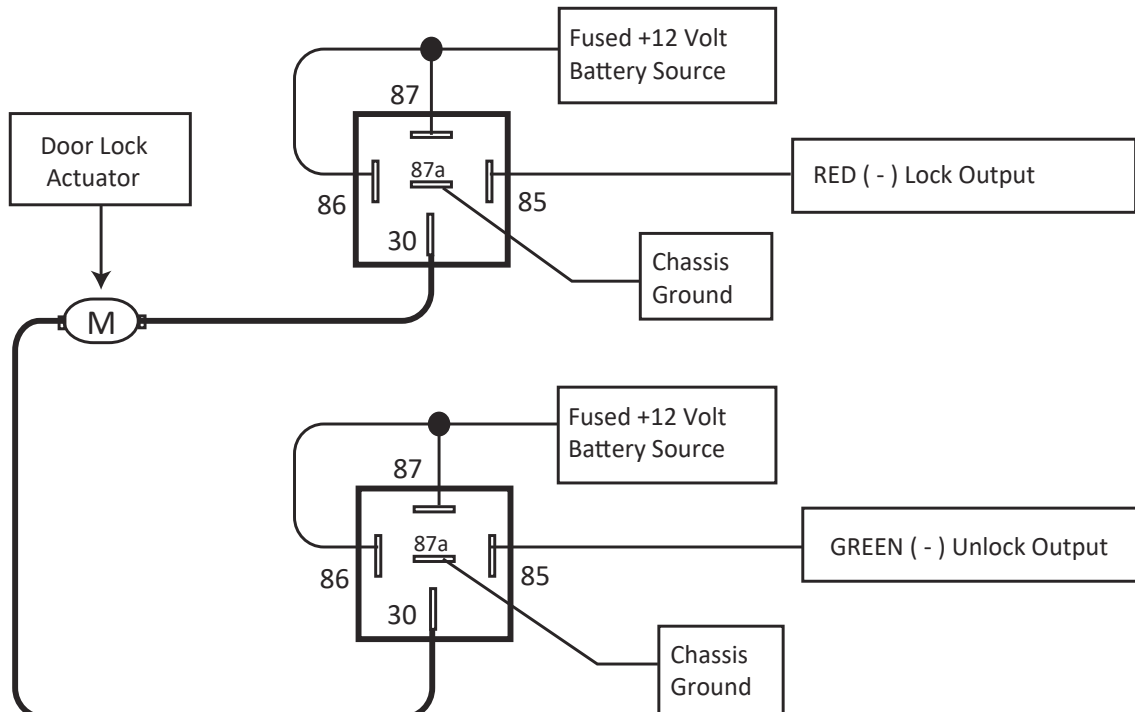

Quick Reference: Wiring Diagrams

Starter Kill / Anti-Grind Relay Connections

Starter Kill / Anti-Grind Relay (Optional)

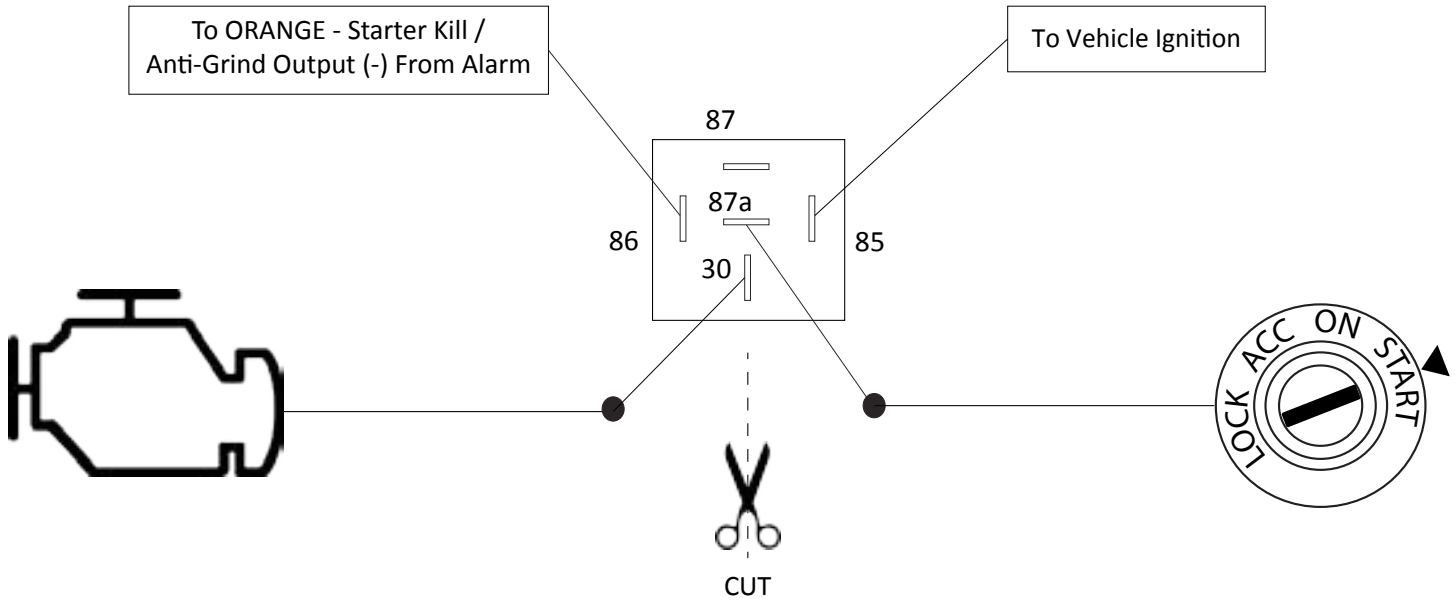

Quick Reference: Wiring Diagrams

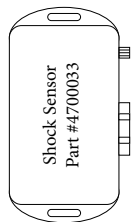

4	Red	Battery 12V (+)
3	Black	Data TX
2	Blue	Warn Away
1	Green	Full Trigger

Replacement Part #4120459

22	Green	Unlock Output (-) (NOC 11)
21	DK. Blue	Trunk Output (-) (NOC 9)
20	Red	Lock Output (-) (NOC 10)
19	Green/Lt. Blue	Ch. 4 AUX Output (-) (NOC 8)
18	Black/White	Horn Output (-)
17	Lt. Blue/Green	Ch. 5 AUX Output (-) (NOC 7)
16	Red/Black	2nd Unlock Output (-) (NOC 12)
15	Black/Lt. Green	Factory Arm Output (-) (NOC 6)
14	Brown/Black	Brake Input (+) (PIC 6)
13	Black/Blue	Factory Disarm Output (-) (NOC 3)
12	DK. Blue/Black	External Activation Input (-) (PIC 5)
11	Black/Red	Pulse After Shutdown Output (-) (NOC 4)
10	Orange/Black	Parking Brake Input (-) (PIC 4)
9	Black/Yellow	Pulse During Crank Output (-) (NOC 3)
8	Green/Yellow	Diodes Glow Plug Input (+) (PIC 3)
7	Green/White	Domelight Output (-) (NOC 2)
6	Purple/Brown	Door Trigger Input (-) (2)
5	Lt. Blue	Remote Start Status Output (-) (NOC 1)
4	Green/Orange	Hood Input (-)
3	Gray/Black	Trunk Trigger Input (-) (PIC 1)
2	Lt. Green	Starter Kill Relay / Anti-Grind Output (-)
1	Orange	Starter Kill Relay / Anti-Grind Output (-)

Replacement Part #4120457

4	Red	Battery 12V (+)
3	Black	Ground (-)
2	Blue	Data TX
1	White	Data RX

Not Included

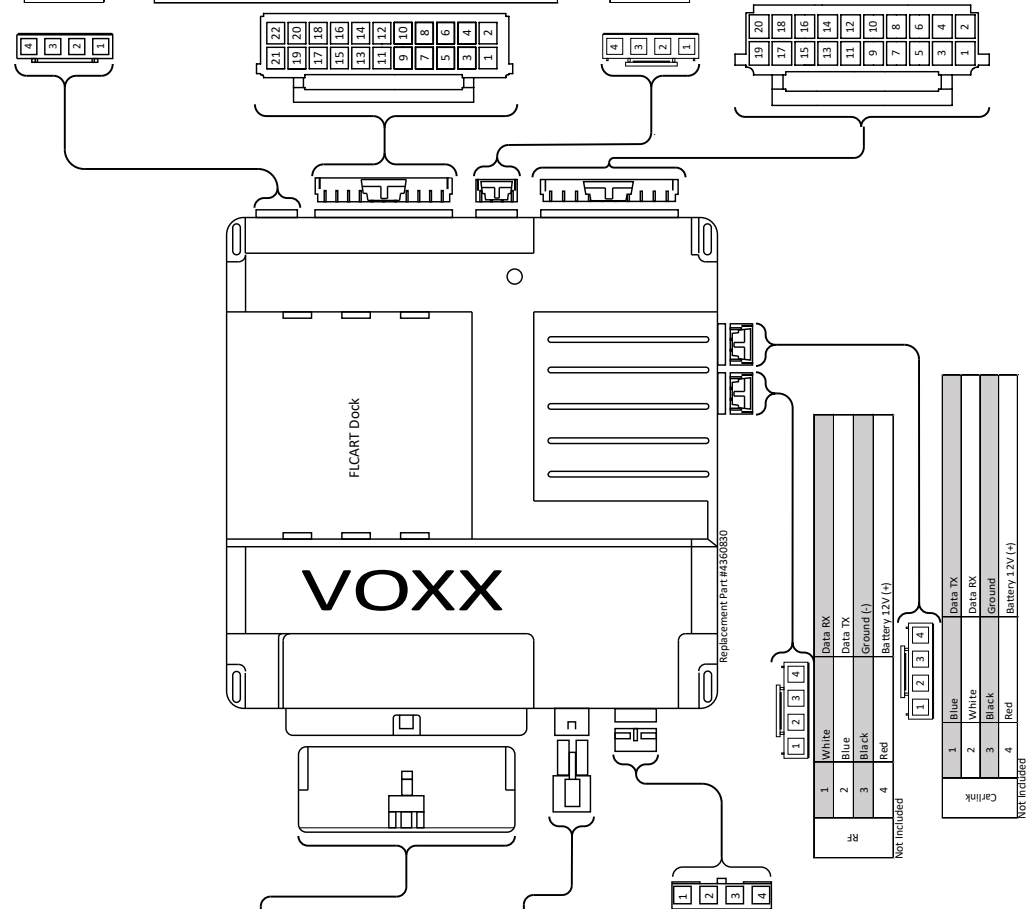

1	Red/Black	Ignition 3 Flex Relay (87) Input
2	Pink	Ignition 3 Flex Relay (30) Output Ⓞ
3	Yellow	Starter Output (+)
4	Green	Ignition 2 Output (+) Ⓞ
5	Red	Battery 12V (+)
6	Red/White	Accessory Output (+) Ⓞ
7	Purple	Ignition 1 Input / Output (+)
8	Blue	Ignition 1 Input / Output (+)

Replacement Part #4120458

1	White	Parking Light (30) Output Ⓞ
2	White/Red	Parking Light (87) Input
3	White/Black	Siren Output (+)
4	Black	Ground Input (-)

Replacement Part #4120462

1	White	Data RX
2	Black	Ground (-)
3	Blue	Data TX
4	Red	Battery 12V (+)

Not Included

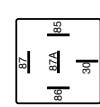

85	Red	Ignition Input (+)
86	Orange	Starter Kill Input (-)
87A	Black	Starter Output - Motor Side
30	Black/White	Starter Input - Key Side

Replacement Part #4336288

This Harness is included with the FLCART.
For Wire Information and Diagram Please Refer to Vehicle Specific
FlashLogic Install Guide.
Visit www.FlashLogic.com for More Information.
Not Included