

# Park Daddy Installation Manual

MODEL PD-50-AA

MODEL PD-100-AA





# TABLE OF CONTENTS

Introduction.....	2
Package Contents.....	3
Unpacking.....	3
Installing Infrared Head Units.....	4
Installing RF Radio Receivers.....	10
Operation.....	12
Alternative Uses.....	13
Programming Alternative Channels.....	14
Restoring Factory Channel Settings.....	15
Warnings.....	16
Product Care.....	17
Troubleshooting.....	18
Warranty.....	20
Disclosures.....	20
Customer Service.....	20
Technical Specifications.....	21
FCC & IC Warnings.....	22
Mounting Template.....	23

## INTRODUCTION

Thank you for purchasing this product from VOXX Electronics. This high quality product has been designed, built and tested to the utmost standards to perform accurately and reliably for many years of satisfied use. Please read and understand the contents of this User Manual before operating this product.



## PACKAGE CONTENTS

- (1) Receiving Infrared Head Unit "A"
  - (1) Transmitting Infrared Head Unit "B"
  - (2) RF Radio Receivers
  - (4) 1" #8 Pan Head Screws
  - (4) Screw Anchors
- (See Figure 1 and Figure 2)

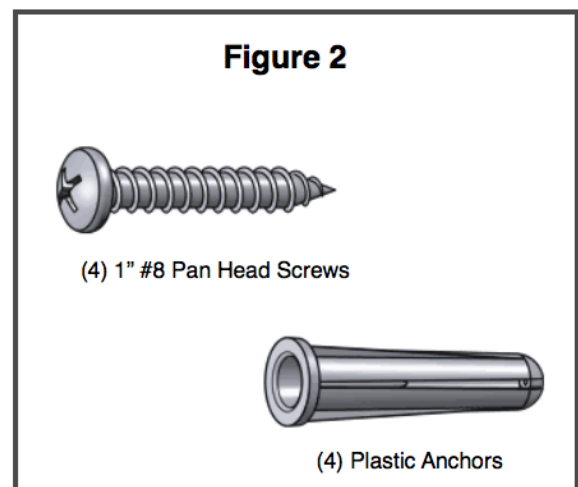
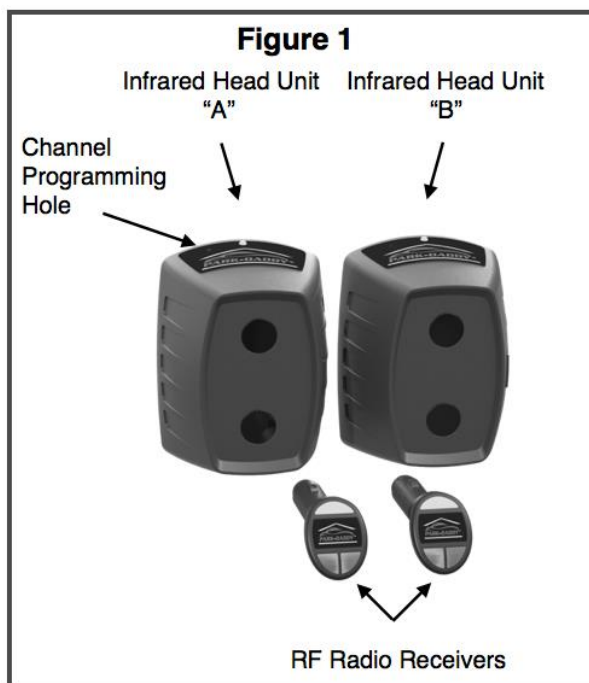

## UNPACKING

1. The product contents are set in a cardboard tray. Carefully remove all of the parts in the tray.
2. Inspect the contents carefully to make sure that no damage or breakage has occurred.
3. Do not discard the packaging material until you have inspected the product, identify all of the parts and successfully operated the product.
4. If any parts are missing or damaged, please contact Customer Service for assistance.



## INSTALLING INFRARED HEAD UNITS

There are 2 Infrared Head Units with this system, “A” and “B”. Infrared Head Unit “A” is marked with the letter “A” on the bottom label and also has a small Channel Programming Hole to the left of the LED on the top of the head unit. Infrared Head Unit “B” is marked with the letter “B” on the bottom label and has only a LED on the top of the head unit. It does not matter which Infrared Head Unit is mounted to each mounting wall. (See Figure 1)

The Park-Daddy® Vehicle Parking System is designed to be mounted in the garage to notify the operator of a vehicle when the rear bumper has cleared the garage door opening and it will be safe to close the garage door, leaving the maximum amount of room in the front of the vehicle. The Park-Daddy® Vehicle Parking System can be used in garages with up to 4 parking spots across.

The Park-Daddy® can also be used as an invisible barrier in the front and the side of the vehicle to warn you when a vehicle is close to objects placed in the garage. For installation instructions for the other alternative uses, please refer to the Alternative Uses section.

## INSTALLING BATTERIES

Each Infrared Head Unit requires (2) D size alkaline batteries to be installed. (Batteries not included.)

1. Remove battery door by pulling down the tab on top of the battery door and pulling the top of the door outward.
2. Hold the Infrared Head Unit in one hand with the opening upward and the top of the Head Unit facing away (The top of the Head Unit has the product label and the LED).
3. Install the first battery with the (+) positive terminal touching the contact in the top end on the battery compartment.
4. While holding the first battery in place with your thumb, place the (-) negative terminal of the second battery on the spring in the lower section of the battery compartment and compress the spring until there is enough clearance for the second battery's (+) positive terminal to make contact with the first battery's (-) negative terminal.
5. Replace the battery door with the tab on the bottom of the door inside the battery compartment first then pull down the locking tab on the top of the door and push the battery door inward until the door completely closes.
6. Repeat the above procedure on the remaining Infrared Head Unit.

**The Red LED on Infrared Head Unit “A” will illuminate and the LED on Infrared Head Unit “B” will flash Green every 15 seconds after batteries are installed until both Infrared Head Units are paired.**





## DETERMINING VEHICLE CLEARANCE

**Locate Mounting Template at the end of this User Manual.**

The distance from the inner part of the garage door and line “B” of the Mounting Template can be determined by the following:

1. With the garage door in the closed position, determine the inner most point of the interior section of the garage door including handles, hinges, supports, hurricane struts or trusses and any other protrusion attached to the interior of the door.
2. Using a pencil, erasable marker or a piece of tape, mark the floor of the garage at each end of the garage door twice approximately 6 inches apart at the inner most point of the interior section of the garage door. Run a straight edge from both marks to the mounting walls and place a mark on the bottom of each mounting wall.
3. By marking the mounting walls as determined in the previous paragraph, you can now find a safe clearance. From that mark you will add different variables such as roll back allowance after putting your car in the park position and releasing the brake and other variables like bumper moldings and trim and/or trailer hitches and trailer hitch receivers. Always add an additional 1 inch safety margin. Example: 1 inch safety margin + 3 inches for roll back + 1 inch for bumper trim = 5 inches clearance.
4. From the marks you made on the mounting walls add the clearance measurement and mark the mounting walls again extending the mark away from the garage door. You now have determined the measurement that will be the placement of line “B” on the Mounting Template. (See Figure 3)



Figure 3

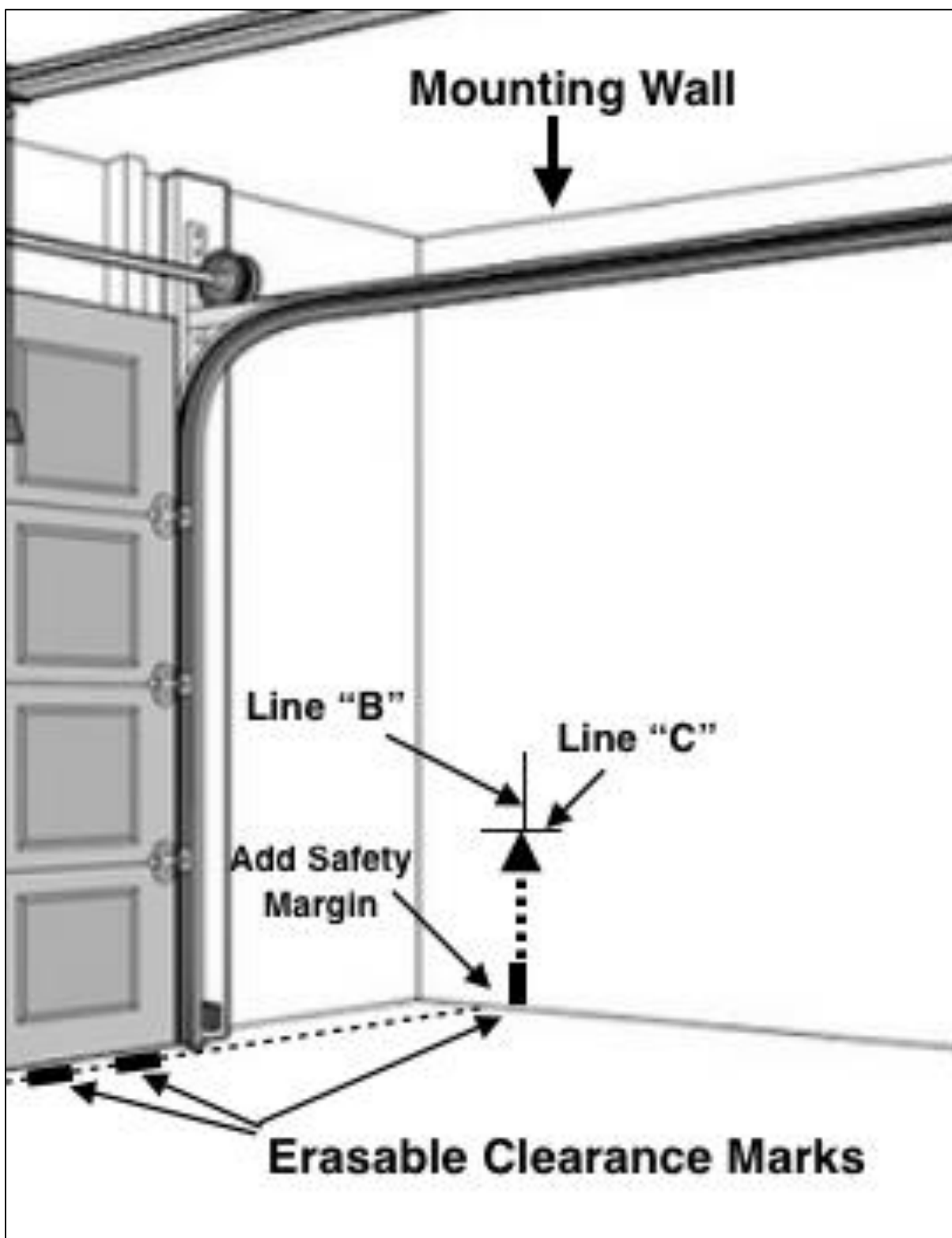

## HEIGHT POSITIONING

Determine the height of the head units. At least one of the two lenses should be at the same height of the face of the rear bumper. An average height rear bumper for most passenger cars up to standard size two wheel drive pickup trucks is 20 to 22 inches from the floor to line “C” on the Mounting Template.

For suggested height placements to line “C”, **for 2 or more vehicle systems**, see Height Chart below:

<b>HEIGHT CHART</b>	
Multiple Passenger Cars	20 Inches
Passenger Cars and Mini Vans	20 Inches
Passenger Cars and SUVs	21 Inches
Passenger Cars and Standard Size 2WD Pickup Trucks	22 Inches*
Mini Vans and SUVs	21 Inches
Mini Vans and Standard Size 2WD Pickup Trucks	22 Inches*
SUVs and Standard Size 2WD Pickup Trucks	22 Inches*
Multiple Standard Size 2WD Pickup Trucks	24 Inches*

\* The Height Chart above is for most vehicle combinations. In cases that involve bumper heights of more than 22 inches from the ground to the bottom of the bumper may require special adjustments to the positioning or may require an additional set of Infrared Head Units.

After the height and the distance from the garage door is determined, you can now mark the height on the mounting walls and intersect that mark with a distance mark by extending a line upward from the distance mark you previously marked on the floor. (See Figure 3)

You are now ready to mount the Infrared Head Units.



## MOUNTING METHODS

There are two different Mounting Methods.

**First cut out the Mounting Template along Line “A” before proceeding.**

### METHOD #1

This method is for easy mounting to **painted** surfaces with smooth to medium textures such as painted wood, drywall with or without texture, concrete or concrete blocks and bricks. **This method is not recommended for heavy textured stucco or unpainted surfaces.**

1. Clean mounting surface with isopropyl alcohol or a mild cleaning solvent before mounting the Infrared Head Units.
2. With the Mounting Template cut out, hold the Mounting Template on the mounting wall and line up line “B” to the distance measurement and line up line “C” to the height measurement. When both lines are lined up, with a pencil, trace the cut out Mounting Template on the wall surface. Repeat this procedure on the opposite mounting wall.
3. Remove the paper backing from the mounting tape on the back of the Infrared Head Unit. Carefully place the Infrared Head Unit to the template outline on the mounting wall. Once in place, firmly press the Infrared Head Unit to the mounting wall to seat the Mounting tape. Repeat on the other mounting wall with the remaining Infrared Head Unit.

**Please be advised that when removing installed Infrared Head Units using this mounting method, it may result in leaving a glue residue on the wall or possibly removing paint from the wall.**





## METHOD #2

This method is for mounting to surfaces with a heavy or course textures or for easy and frequent removals.

1. With the Mounting Template cut out, hold the Mounting Template on the mounting wall and line up line "B" to the distance measurement and line up line "C" to the height measurement. When both lines are lined up, with a pencil, place a mark for each mounting hole as shown as "D" on the Mounting Template. Repeat this procedure on the opposite mounting wall.
2. Drill a 3/16" hole at each mounting hole mark. Insert a plastic anchor in each hole.
3. Screw the 1" #8 screws into the plastic anchors; leave a distance of 1/8" from the top of the plastic anchor to the bottom of the screw head as shown. (See Figure 4)

Figure 4

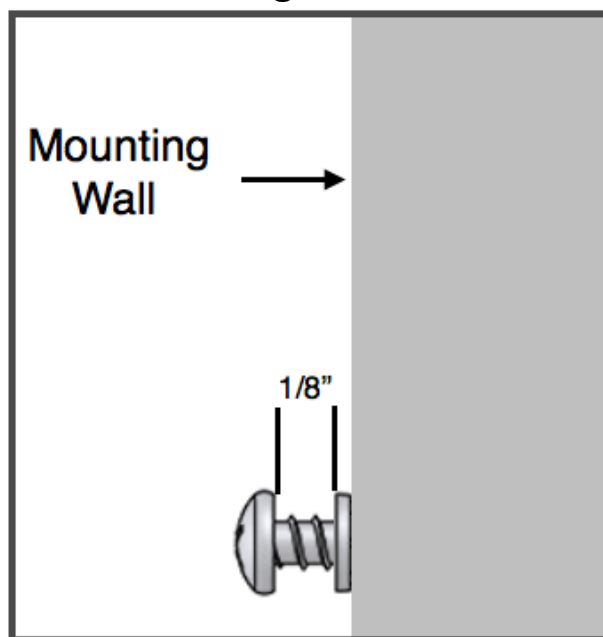

4. Place the heads of the inserted mounting screws through the mounting holes on the back of the Infrared Head Units and pull downward slightly to seat the mounting screws.



The Infrared Head Units are now mounted and should be automatically paired.

To confirm that the Infrared Head Units are paired, you will see a short green flash every 15 seconds from the LEDs on the top of each Infrared Head Unit. If the LED on Infrared Head Unit "A" has a steady RED, the Infrared Head Units are not paired properly. Refer to the Trouble Shooting section.

If you do not see a flashing green LED, refer to the Trouble Shooting section of this User Manual.

**If at any time the LED flashes RED every 15 seconds, the battery voltage is low and the batteries will need to be replaced immediately to ensure safe operation of the system.**

**Although very rare, when testing the system and you find the garage door opener is malfunctioning, swap Infrared Head Unit A with Infrared Head Unit B and vice versa. This procedure should stop any interference with the garage door safety sensors. Always check to be sure the garage door opener safety sensors are functioning properly before use.**

## INSTALLING THE RF RADIO RECEIVER

1. Installing the RF Radio Receiver is as easy as plugging it into the DC cigarette lighter port. The status indicator located on the top of the face of the RF Radio Receiver will glow green or red. (Green if the infrared beams are unobstructed and Red if the infrared beams is blocked). (See Figure 5)
2. Adjust the RF Radio Receiver to the desired position by rotating the unit and swiveling the upper portion up or down.
3. Adjust the desired volume of the tone by depressing the (-) or (+) buttons located on the lower portion of the face of the RF Radio Receiver. (See Figure 5)



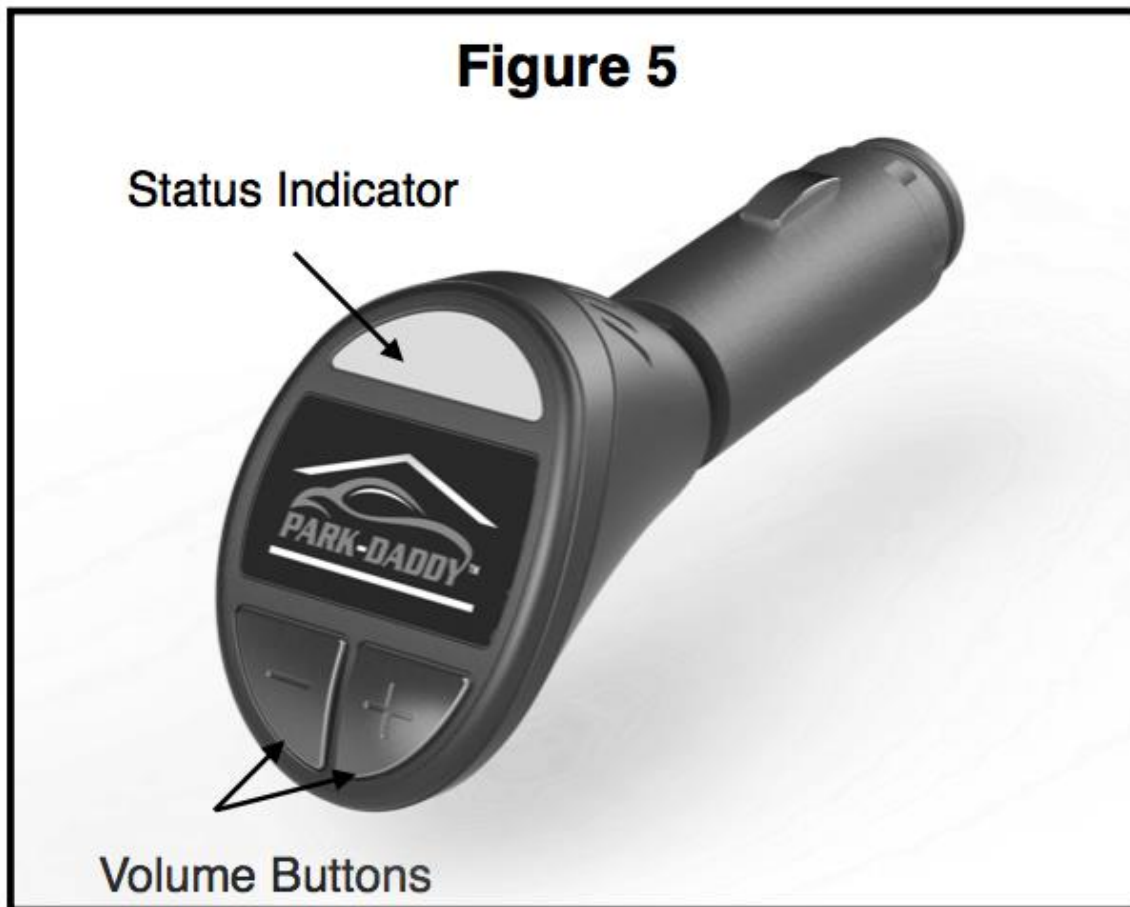

If either one of the functions above are not operating correctly, refer to the Trouble Shooting section of this User Manual.

You are now ready to proceed to the Operation section.



# OPERATION

This section pertains to the operation of the Park-Daddy® Vehicle Parking System with the Infrared Head Units mounted in the garage to notify the operator of a vehicle when the rear bumper has cleared the garage door opening.

**Before using the Park-Daddy® for the first time, release the garage door from the garage door opener and manually check the clearance between the vehicles and the garage door.**

For operation as an invisible barrier in the front and the side of the vehicle, please refer to the Alternative Uses section.

1. With the Infrared Head Units mounted and the RF Radio Receiver plugged into the DC cigarette lighter port and the Status Indicator on the RF Radio Receiver is glowing Green, drive the vehicle slowly into the garage. When the infrared beams are blocked by the vehicle, the Status Indicator on the RF Radio Receiver will glow Red and the warning tone will sound.
2. Proceed into the garage slowly. Once the Status Indicator has returned to glowing Green and the warning tone stops, stop the vehicle.
3. **VEHICLES WITH AUTOMATIC TRANSMISSIONS:**  
After you have stopped your vehicle, place the transmission into the Park position and take your foot off the brake pedal, to allow for any roll back. Make sure the Status Indicator is glowing Green. Now you can turn off your vehicle.

### **VEHICLES WITH MANUAL TRANSMISSIONS:**

After you have stopped your vehicle, either set your parking brake or put your vehicle in gear, turn off the motor, keep the ignition switch in the accessory position to allow power to the DC cigarette lighter port and take your foot off the brake and clutch peddles, to allow for any roll back. Make sure the Status Indicator is glowing green. Now you can turn your ignition switch completely off.

4. Now it is safe to close your garage door.





## ALTERNATIVE USES

The Park-Daddy® Vehicle Parking System can also be used as a safety barrier for the side or the front of vehicles, notifying the operator of any obstructions. These alternative uses are not suggested unless the operator has adequate reflexes to stop the vehicle when the barrier has been crossed.

1. Find the height and clearance measurements. Always factor in any moldings, handles, mirrors or any other protrusions when determining the clearance measurement. Also, it is essential to factor in an adequate stopping distance in your clearance measurement.
2. Refer to the Mounting Methods section of this User Manual.
3. Refer to the Installing RF Radio Receiver section of this User Manual.
4. The RF Radio Receiver will operate the same as described in the Operation section, but when the vehicle crosses the infrared beam, you will need to stop immediately when the Status Indicator on the RF Radio Receiver illuminates Red and the tone sounds.





## PROGRAMMING ALTERNATIVE CHANNEL

An Alternative Channel can be programmed to the system in the event another Park-Daddy® system is in operation in the close vicinity and is causing interference while operating your system. To program an alternative channel, follow these steps:

1. Make sure the RF Radio Receivers being programmed are within 50 feet of the Infrared Head Units and no vehicles or any other objects are blocking the Infrared Head Units.
2. Using a thin object such as a toothpick, paper clip, etc., insert that object into the Channel Programming Hole in Infrared Head Unit “A” as shown in Figure 1 and hold the switch under the hole down for 5 seconds until the LED on Infrared Head Unit “A” flashes Green rapidly.
3. With the RF Radio Receiver powered up, press the (-) and (+) volume buttons down at the same time for 5 seconds until the Status Indicator flashes Red for 5 seconds and then illuminates Green. Once Green, the RF Radio Receiver is programmed.
4. Repeat the procedure in paragraph #3 for a second and any additional RF Radio Receives being used with the reprogrammed system. **If other RF Radio Receivers are not reprogrammed, they will not work with the system.**
5. Once all the RF Radio Receivers are re-programmed, insert the thin object you used before into the Channel Programming Hole in Infrared Head Unit “A” and press the switch quickly once to put Infrared Head Unit back to the normal operating mode. The Alternative Channel is now programmed.





# RESTORING FACTORY CHANNEL SETTINGS

To restore the Park-Daddy® system to the Factory Channel Settings, follow these steps:

1. Make sure the RF Radio Receivers being programmed are within 50 feet of the Infrared Head Units and no vehicles or any other objects are blocking the Infrared Head Units.
2. Using a thin object such as a toothpick, paper clip, etc., insert the object into the Channel Programming Hole in Infrared Head Unit “A” as shown in **Figure 1** and hold the switch under the hole down for 10 seconds until the LED on Infrared Head Unit “A” flashes Green rapidly and then rapidly flashes **Red**.
3. With the RF Radio Receiver powered up, press the (-) and (+) volume buttons down at the same time for 5 seconds until the Status Indicator flashes Red for 5 seconds and then illuminates Green. Once Green, the RF Radio Receiver is programmed.
4. Repeat the procedure in paragraph #3 for a second and any additional RF Radio Receives being used with the reprogrammed system. **If other RF Radio Receivers are not reprogrammed, they will not work with the system.**
5. Once all the RF Radio Receivers are re-programmed, insert the thin object you used before into the Channel Programming Hole in Infrared Head Unit “A” and press the switch quickly once to put Infrared Head Unit back to the normal operating mode. The Factory Channel Settings are now programmed.

**FOR MORE INFORMATION ON THE SETUP OF THIS PRODUCT, GO TO THE INSTALLATION AND OPERATION INSTRUCTIONS VIDEO IN THE PARK-DADDY™ VIDEOS PAGE AT: [WWW.PARK-DADDY.COM](http://WWW.PARK-DADDY.COM).**





## WARNINGS

- When using this product while sitting in a motor vehicle, check for pedestrians, pets and objects around you.
- Roll back may occur when a vehicle is in the Park position and the brake is released. Always let the vehicle settle into position before shutting off the vehicle. It is always good practice to add a 1 inch safety margin plus a 3 inch roll back margin to insure a safe clearance from the interior of the garage door to the outer most point of your rear bumper when installing Infrared Head Units.
- Human error can occur when installing the system. Always check your clearances before the first use by disengaging the garage door opener and manually shutting the garage door slowly and visually inspecting the clearance with the vehicle(s) in the parked position.
- Occasional disruption to the Infrared and Radio signals do to interference from other sources may cause a deviation in accuracy and range.
- Low battery power may affect the operation of this system.
- If infrared beams are blocked for an excessive period of time or if the Infrared Head Units are not paired with the batteries installed, battery power will deplete faster than normal operation.
- Extra weight in back of the vehicle or trunk may change the proper height setting for the Infrared Head Units.
- Do not look directly into any of the indicator LEDs installed in any part of this product at a close range for a long period of time.
- Do not submerge in water.
- Do not expose this product outdoors to raining, icing or snowing conditions.
- Do not leave this product in extreme heat for long periods of time.
- Low temperatures can affect the life of the batteries.
- Do not use abrasives, harsh cleaners or chemicals when cleaning this product.
- Opening the housings of the Infrared Head Units or RF Radio Receiver may cause damage to the product and will void the warranty.







- Do not modify this product in any way. Doing so will void the warranty.
- This product is designed to be used on flat, level, and hard surfaces. Using this product on surfaces other than those described above may create difficulty when trying to pair the Infrared Head Units.
- For disposal of batteries, follow the battery manufactures' guidelines for proper disposal.
- Never dispose of any batteries in fire because they could explode.
- Always replace batteries immediately when the LEDs on the top of the Infrared Head Units flash RED indicating low battery voltage.
- Do not attempt to park more than one vehicle at the same time using a single system or multiple systems.
- Although a very rare occurrence, infrared signals emitted from the Park-Daddy can cause interference to the garage door opener safety sensors. Be sure to check the functionality for the garage door safety sensors after installation. Always check to be sure the garage door opener safety sensors are functioning properly before use.

## PRODUCT CARE

To avoid damage to the optic lenses, clean by wiping with a soft, damp cloth. Do not use abrasives, harsh cleaners or chemicals to clean any part of the product. If any part of the product becomes wet, wipe off immediately with a soft, absorbent cloth. Do not submerge this product in any liquid or clean with running water.





## TROUBLE SHOOTING

**A. Red LED on Infrared Head Unit “A” is illuminated. (Infrared Head Units are not paired properly.)**

1. Check to see if both Infrared Head Units are mounted identically with the same height and clearance measurements.
2. Check for obstructions that are blocking the path of the beam.
3. Check the appearance of the lenses on both Infrared Head Units. If necessary clean by wiping with a soft, damp cloth.
4. Remove and re-install the batteries in both Infrared Head Units.
5. Install new batteries in both Infrared Head Units.
6. If the Red LED is still on after trying steps 1, 2, 3 and 4, call Customer Service.

**B. Green LED on top of either Infrared Head Unit does not flash every 15 seconds or the Red LED on Infrared Head Unit “A” is not illuminated.**

1. Batteries are fully discharged or batteries are not properly installed.
2. If the Green LED is still not flashing after trying step 1, call Customer Service.

**C. The LED on the top of one or both Infrared Head Units flashes RED every 5 seconds.**

1. Low Battery power. Replace batteries immediately.
2. Check to see if the batteries are in the proper position.

**D. Garage door opener malfunctions after installing the Park-Daddy®.**

*Although a very rare occurrence, the Park-Daddy® could interfere with the garage door safety sensors causing a malfunction. Swap Infrared Head Unit A with Infrared Head Unit B and vice versa. This procedure should stop any interference.*

**E. No color illuminating from the status indicator and no tone on the RF Radio Receiver.**

1. Make sure your ignition switch in your car is turned on.
2. Check to see if you have power to the DC cigarette lighter port. If not, check the fuse in your car.
3. Check the fuse in the RF Radio Receiver by unscrewing the tip of the bottom portion of the RF Radio Receiver.
4. Perform a hard reset by unplugging the RF Radio Receivers from the DC ports, remove and re-install the batteries in both Infrared Head Units.
5. Refer to RESTORING FACTORY CHANNEL SETTINGS section on page 12.
6. If steps 1, 2, 3, 4, and 5 did not correct the problem, call Customer Service.





**F. No color illuminating from the Status Indicator, but the tone sounds on the RF Radio receiver.**

*Internal problem - Call Customer Service.*

**G. Volume control does not work and/or no tone sounding, but the Status Indicator illuminates on the RF Radio Receiver.**

*Internal problem - Call Customer Service.*

**IF THERE ARE ANY OTHER TECHNICAL PROBLEMS WITH THIS PRODUCT THAT IS NOT MENTIONED ABOVE, PLEASE CALL CUSTOMER SERVICE.**

**For customer or technical support please call VOXX support:**

**1-800-371-7725**

**9am – 9pm (Eastern) Mon – Friday**

**10am – 2pm (Eastern) Sat**





## **90-DAY LIMITED WARRANTY PARK-DADDY®**

VOXX ELECTRONICS CORPORATION warrants this product to be free of defects in parts and workmanship for **90-days** from date of purchase. If it becomes necessary to return the product for service or replacement during the warranty period, contact the Customer Service Department by calling 1-800-371-7725 for a return authorization. A Return Authorization Number must be issued before any product can be returned. This warranty does not apply to defects resulting from action of the user such as abuse, dropping, water damage, heat damage, improper maintenance, chemical damage, modifications or opening of the housings. In the event that a product is sent back to VOXX ELECTRONICS CORPORATION for a warranty claim and is found to have damage due to one or more of the unwarrantable conditions listed above, the customer that sent the product back will be charged for reimbursement of the return shipping charge, outgoing shipping charge and for any service performed to the returned product. VOXX ELECTRONICS CORPORATION's responsibility for a defective product is limited to repair or replacement of the defective product, as stated above. VOXX ELECTRONICS CORPORATION will not be liable for any other direct, indirect, incidental or consequential damages of any nature.

**THERE ARE NO WARRANTIES WHICH EXTEND BEYOND THE NINETY DAY LIMITED WARRANTY STATED ABOVE, ALL IMPLIED WARRANTIES, INCLUDING BUT NOT LIMITED TO IMPLIED WARRANTIES OF MERCHANTABILITY AND FITNESS FOR A PARTICULAR PURPOSE, ARE EXCLUDED.**

## **DISCLOSURES**

**VOXX Intl. and its distributors and authorized retailers are not responsible for any damages to property, people or pets caused by improper installation, low battery power, interference to radio or infrared signals or operator error.**

**For customer or technical support please call VOXX support:**

**1-800-371-7725**

**9am – 9pm (Eastern) Mon – Friday**

**10am – 2pm (Eastern) Sat**



# TECHNICAL SPECIFICATIONS

<b>Operating Temperature Range:</b>	-4 - 130°F (-20 - 54°C)
<b>Total Shipping Weight:</b>	2.6 Lbs. (1.2 Kg)
<b>IR Head Unit Pairing Range:</b>	5 – 100 ft. (1.5 – 30.5 m)
<b>Precision Over Full Pairing Range:</b>	Approximately 1/8 in. (3.2 mm)
<b>IR Head Unit Battery Requirements:</b>	(2) D Size Alkaline Batteries per Unit
<b>Receiving IR Head Unit “A” Run Time with New Batteries:</b>	Typically One Year
<b>Transmitting IR Head Unit “B” Run Time with New Batteries:</b>	Typically One Year
<b>RF Radio Receiver Range:</b>	0 – 100 ft. (0 – 30.5 m)
<b>RF Radio Receiver Power:</b>	12V DC
<b>RF Frequency of Operation:</b>	916.25 MHz to 917.75 MHz
<b>RF Radio Receiver Fuse Type:</b>	1Amp, 250v, , 20 X 5 mm, glass tube



## FCC WARNINGS

CAUTION: VOXX ELECTRONICS CORPORATION is not responsible for any changes or modifications not expressly approved by the party responsible for compliance. Such modifications could void the user's authority to operate the equipment.

### RADIO AND TELEVISION INTERFERENCE

This equipment has been tested and found to comply with the limits, pursuant to Part 15 of the FCC rules. These limits are designed to provide reasonable protection against harmful interference in a residential installation. This equipment generates, uses and can radiate radio frequency energy and, if not installed and used in accordance with the instructions, may cause harmful interference to radio communications.

However, there is no guarantee that interference will not occur in a particular installation. If this equipment does cause harmful interference to radio or television reception, which can be determined by turning the equipment off and on, the user is encouraged to try to correct the interference by one or more of the following measures.

- Reorient or relocate the receiving antenna.
- Increase the separation between the equipment and the receiver.
- Connect the equipment into an outlet on a circuit different from that to which the receiver is connected.
- Consult the dealer or an experienced radio/TV technician for help.

You may also find helpful the following booklet, prepared by the FCC: "How to Identify and Resolve Radio-TV Interference Problems." This booklet is available from the U.S. Government Printing Office, Washington D.C. 20402.

Changes and Modifications not expressly approved by the manufacturer or registrant of this equipment can void your authority to operate this equipment under Federal Communications Commission's rules.

## IC WARNINGS

This device complies with Industry Canada license-exempt RSS standard(s). Operation is subject to the following two conditions: (1) this device may not cause interference, and (2) this device must accept any interference, including interference that may cause undesired operation of the device.

Le présent appareil est conforme aux CNR d'Industrie Canada applicables aux appareils radio exempts de licence. L'exploitation est autorisée aux deux conditions suivantes : (1) l'appareil ne doit pas produire de brouillage, et (2) l'utilisateur de l'appareil doit accepter tout brouillage radioélectrique subi, même si le brouillage est susceptible d'en compromettre le fonctionnement.

Under Industry Canada regulations, this radio transmitter may only operate using an antenna of a type and maximum (or lesser) gain approved for the transmitter by Industry Canada. To reduce potential radio interference to other users, the antenna type and its gain should be so chosen that the equivalent isotropically radiated power (e.i.r.p.) is not more than that necessary for successful communication.

Conformément à la réglementation d'Industrie Canada, le présent émetteur radio peut fonctionner avec une antenne d'un type et d'un gain maximal (ou inférieur) approuvé pour l'émetteur par Industrie Canada. Dans le but de réduire les risques de brouillage radioélectrique à l'intention des autres utilisateurs, il faut choisir le type d'antenne et son gain de sorte que la puissance isotrope rayonnée équivalente (p.i.r.e.) ne dépasse pas l'intensité nécessaire à l'établissement d'une communication satisfaisante.

